



204 and 304 Series 2-Way and 3-Way Small Direct Acting Solenoid Valves

Catalog 204304S0407



Key Features

Performance

- Tested to 20 million cycles
- Tight tolerances yields valve to valve repeatability
- Material selection provides higher pressure ratings for ambient temperature
- All ratings per agency standards including operation at 85% of rated voltage

COIL

- Class F is standard for higher temperature compatibility
- Coil Selections includes: Tabs, Leads, NEMA 4X and Conduit

BODY

- 303 Stainless Steel is standard
- SAE sleeve flange to body seal for trouble-free installation and service

SLEEVE

- Improved magnetic design for higher pressure ratings
- Precision laser welds for durability and repeatability
- Copper shading ring in all sleeves for AC & DC coil interchange

SEALS

- Viton™ Seals are standard for broader fluid compatibility

User Friendly

- Assembly and disassembly does not require special tools
- Conduit Hub is rotatable for ease of conduit assembly

Type 4X Coil Features

Water-tight coil designs to meet demanding environmental conditions.

Molded lead seal prevents moisture entry

Conduit o-ring seal

Patent pending NEMA 4X coil with rotating conduit hub

Class F and H ratings for high temperature conditions and dependable performance

Top & bottom o-ring seals prevent moisture ingress

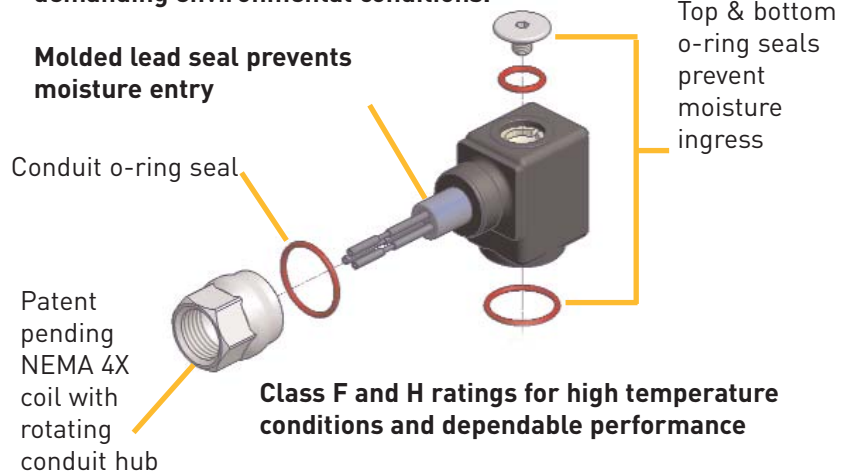
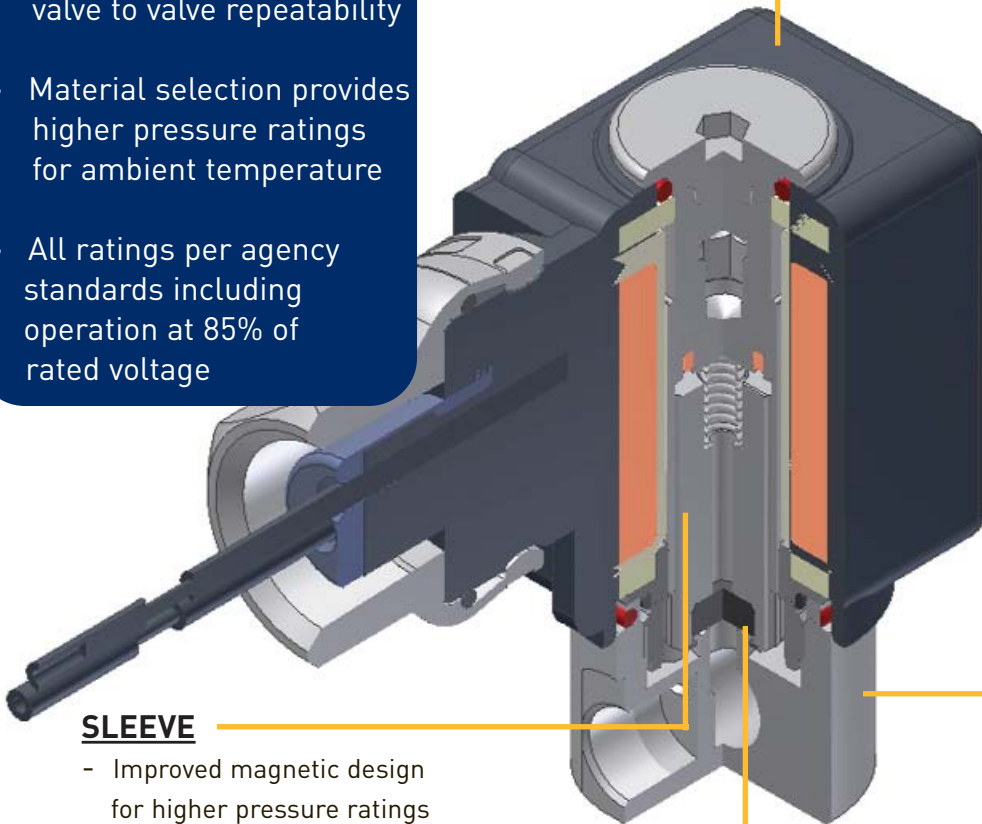

204 & 304 Series

TABLE OF CONTENTS

How to Order	2
Technical Specifications for Series 204 and 304	3
2-Way Series 204 Direct Acting	3
3-Way Series 304 Direct Acting	4
2-Way and 3 Way Dimensional Drawings	5
Coil Information	6
2-Way Series Cartridge Valve Information	7
3-Way Series Cartridge Valve Information	8
Valve Numbering System	9
Electrical Data Information	10
Options	11-12
Coil Chart	Open Back Cover

WARNING!

FAILURE OR IMPROPER SELECTION OR IMPROPER USE OF THE PRODUCTS AND/OR SYSTEMS DESCRIBED HEREIN OR RELATED ITEMS CAN CAUSE DEATH, PERSONAL INJURY AND PROPERTY DAMAGE.

This document and other information from Parker Hannifin Corporation, its subsidiaries and authorized distributors provide product and/or systems options for further investigation by users having technical expertise. It is important that you analyze all aspects of your application and review the information concerning the product or system in the current product catalog. Due to the variety of operating conditions and applications for these products or systems, the user, through its own analysis and testing, is solely responsible for making the final selection of the products and systems and assuring that all performance, safety and warning requirements of the application are met.

The products described herein, including without limitation, product features, specifications, designs, availability and pricing, are subject to change by Parker Hannifin Corporation and its subsidiaries at anytime without notice.

HOW TO ORDER

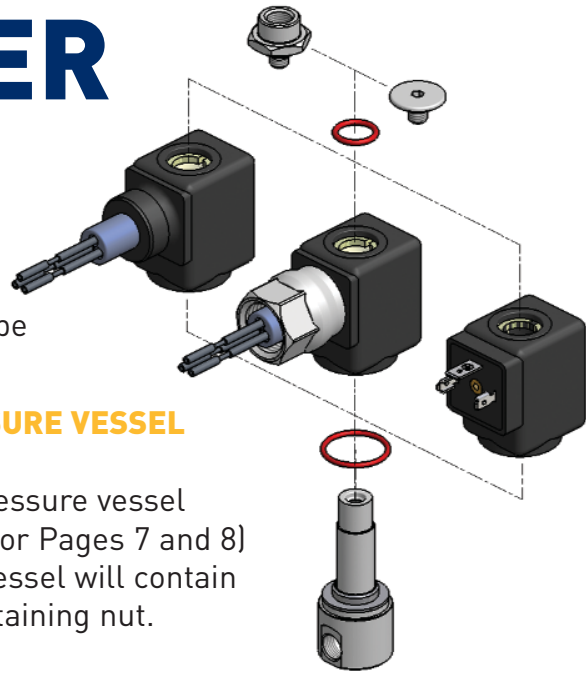

Modular Units: Our solenoid valves can be ordered in two parts: pressure vessel and solenoid coil.

With modularity, order the pressure vessel and mix and match 3 different coil styles to match your application requirement.

The available modular coils consist of the following coils displayed on the flip out tab attached to the back cover:

- C4 conduit coil
- B4 leaded coil
- D6 DIN coil

TO ORDER PRESSURE VESSEL

- Choose your pressure vessel (Pages 3 and 4 or Pages 7 and 8)
The pressure vessel will contain the required retaining nut.

TO ORDER COIL

- Fold out back cover to reveal the Coil Options for Modular Ordering
- Go to standard voltages and select voltage
- Add Standard Voltage Code to end of Coil Code
- * The coil assembly will contain the O-ring seals.
- * Coils carry **CAI**® us recognition.

Assembled Valve Units: To Order a complete Valve follow these 3 Easy Steps.

Step 1: Select the pressure vessel catalog number found on page 3 and 4 of the catalog.

Step 2: Turn to page 6 and choose the coil. Add the 2 digit Coil Code to the pressure vessel number.

Step 3: Lastly, go to the bottom of page 6 and add the 1 digit voltage code at the end of the part number after the coil code.



3 Way Series 304 Direct Acting Valves - Parker											
DESIGN UNITS						METRIC UNITS					
Part No.	Flare	CS	Flare	CS	Flare	Part No.	Flare	CS	Flare	CS	Flare
1.0 132 0.00	1.34	0.007	0	200	200	1.0 132 0.00	1.34	0.007	0	200	200
1.0 134 0.00	1.34	0.005	0	200	200	1.0 134 0.00	1.34	0.005	0	200	200
1.0 136 0.00	1.36	0.010	0	200	200	1.0 136 0.00	1.36	0.010	0	200	200
1.0 138 0.00	1.38	0.015	0	200	200	1.0 138 0.00	1.38	0.015	0	200	200
1.0 140 0.00	1.40	0.020	0	200	200	1.0 140 0.00	1.40	0.020	0	200	200
1.0 142 0.00	1.42	0.025	0	200	200	1.0 142 0.00	1.42	0.025	0	200	200
1.0 144 0.00	1.44	0.030	0	200	200	1.0 144 0.00	1.44	0.030	0	200	200
1.0 146 0.00	1.46	0.035	0	200	200	1.0 146 0.00	1.46	0.035	0	200	200
1.0 148 0.00	1.48	0.040	0	200	200	1.0 148 0.00	1.48	0.040	0	200	200
1.0 150 0.00	1.50	0.045	0	200	200	1.0 150 0.00	1.50	0.045	0	200	200
1.0 152 0.00	1.52	0.050	0	200	200	1.0 152 0.00	1.52	0.050	0	200	200
1.0 154 0.00	1.54	0.055	0	200	200	1.0 154 0.00	1.54	0.055	0	200	200
1.0 156 0.00	1.56	0.060	0	200	200	1.0 156 0.00	1.56	0.060	0	200	200
1.0 158 0.00	1.58	0.065	0	200	200	1.0 158 0.00	1.58	0.065	0	200	200
1.0 160 0.00	1.60	0.070	0	200	200	1.0 160 0.00	1.60	0.070	0	200	200
1.0 162 0.00	1.62	0.075	0	200	200	1.0 162 0.00	1.62	0.075	0	200	200
1.0 164 0.00	1.64	0.080	0	200	200	1.0 164 0.00	1.64	0.080	0	200	200
1.0 166 0.00	1.66	0.085	0	200	200	1.0 166 0.00	1.66	0.085	0	200	200
1.0 168 0.00	1.68	0.090	0	200	200	1.0 168 0.00	1.68	0.090	0	200	200
1.0 170 0.00	1.70	0.095	0	200	200	1.0 170 0.00	1.70	0.095	0	200	200
1.0 172 0.00	1.72	0.100	0	200	200	1.0 172 0.00	1.72	0.100	0	200	200
1.0 174 0.00	1.74	0.105	0	200	200	1.0 174 0.00	1.74	0.105	0	200	200
1.0 176 0.00	1.76	0.110	0	200	200	1.0 176 0.00	1.76	0.110	0	200	200
1.0 178 0.00	1.78	0.115	0	200	200	1.0 178 0.00	1.78	0.115	0	200	200
1.0 180 0.00	1.80	0.120	0	200	200	1.0 180 0.00	1.80	0.120	0	200	200
1.0 182 0.00	1.82	0.125	0	200	200	1.0 182 0.00	1.82	0.125	0	200	200
1.0 184 0.00	1.84	0.130	0	200	200	1.0 184 0.00	1.84	0.130	0	200	200
1.0 186 0.00	1.86	0.135	0	200	200	1.0 186 0.00	1.86	0.135	0	200	200
1.0 188 0.00	1.88	0.140	0	200	200	1.0 188 0.00	1.88	0.140	0	200	200
1.0 190 0.00	1.90	0.145	0	200	200	1.0 190 0.00	1.90	0.145	0	200	200
1.0 192 0.00	1.92	0.150	0	200	200	1.0 192 0.00	1.92	0.150	0	200	200
1.0 194 0.00	1.94	0.155	0	200	200	1.0 194 0.00	1.94	0.155	0	200	200
1.0 196 0.00	1.96	0.160	0	200	200	1.0 196 0.00	1.96	0.160	0	200	200
1.0 198 0.00	1.98	0.165	0	200	200	1.0 198 0.00	1.98	0.165	0	200	200
1.0 200 0.00	2.00	0.170	0	200	200	1.0 200 0.00	2.00	0.170	0	200	200



Coil Information
Encapsulated Watertight Designs. Available as Modular Coils or for Fully Assembled Valves.

<p>Conduit Coil Coil Code: C4*</p> <p>Construction:</p> <ul style="list-style-type: none"> Class F 1/2" lead wires Classed wire 1/2" PTFE conductive hub NEMA 4X, IP67 protection AC: 20 Watts average 2 Wire Normally Closed 0.5 Watts DC: 8 Watts 	<p>Leaded Coil Coil Code B4*</p> <p>Construction:</p> <ul style="list-style-type: none"> Class F 1/2" lead wires Classed wire 1/2" PTFE conductive hub NEMA 4X, IP67 protection AC: 20 Watts average 2 Wire Normally Closed 0.5 Watts DC: 8 Watts 	<p>DIN Coil Coil Code D6*</p> <p>Construction:</p> <ul style="list-style-type: none"> Class F 1/2" lead wires 1/2" PTFE conductive hub NEMA 4X, IP67 protection AC: 20 Watts average 2 Wire Normally Closed 0.5 Watts DC: 8 Watts
--	--	---

Coil Information
Conventional Coil & Enclosures for Fully Assembled Valves Only

<p>Grommet Coil Coil Code B2*</p> <p>Construction:</p> <ul style="list-style-type: none"> Resistance protection Shielded grommet coil Class F 1/2" leads - 2 wire AC: 20 Watts DC: 8 Watts 	<p>Leaded Coil Coil Code L2*</p> <p>Construction:</p> <ul style="list-style-type: none"> 1/2" lead wires Classed wire 1/2" PTFE conductive hub NEMA 4X, IP67 protection AC: 20 Watts average 2 Wire Normally Closed 0.5 Watts DC: 8 Watts 	<p>Tab Coil Coil Code T2*</p> <p>Construction:</p> <ul style="list-style-type: none"> 1/2" lead wires Classed wire 1/2" PTFE conductive hub NEMA 4X, IP67 protection AC: 20 Watts average 2 Wire Normally Closed 0.5 Watts DC: 8 Watts
---	---	--

* ADD VOLTAGE CODE: A=12VDC B=24VDC C=48VDC D=120VAC E=240VAC F=120VAC/110VAC G=240VAC/220VAC



2-Way and 3-Way Technical Specs



Mechanical Characteristics

Body: 303 Stainless Steel
 Sleeve: Stainless Steel
 Plunger: Stainless Steel
 Seals: FKM (Viton™)
 Shading Ring: Copper
 Spring: Stainless Steel

Mounting

Any orientation is permissible

Electrical Characteristics

Encapsulated Coils are one piece molded units available with the choice of Flying Leads, ½" NPT Conduit, or DIN 43650A.

Conventional Coils are multiple piece units available with the coil as Flying Leads or ¼" Tabs plus the enclosure as Grommet or Yoke Frame as appropriate for the coil construction.

Class F 155°C is standard 100% Continuous Duty Rating

Standard Voltages & Part Number Codes:

12VDC	A
24VDC	B
24/60	E
110/50-120/60	F
220/50-240/60	G

Power Consumption

Power 8 to 10 Watts
 See Page 6 for Coil details

Operating Characteristics

△ minimum 0
 △ maximum see tables
 Max. Fluid Viscosity (300 SSU)

Environmental Temperature Ranges

AC Ambient Temperature Range

*32°F (0°C) to 135°F (57°C)

DC Ambient Temperature Range

* 32°F (0°C) to 125°F (52°C)

AC Media Temperature Range

* 32°F (0°C) to 180°F (82°C)

DC Media Temperature Range

* 32°F (0°C) to 185°F (82°C)

* In the absence of moisture, applications as low as -20°F (-29°C) are possible.

Compatible Fluids

Lubricated Air, non-Lubricated Air, Inert Gases, Water, Petroleum Products and additional fluids compatible with the materials of construction. Pressure ratings apply to all compatible fluids within stated temperature ranges.

Optional Construction

Consult Fluid Control Division for alternate materials, alternate coil features including Class H 185°C , other voltage needs etc.

Weight including Conduit Coil:

2-way normally closed 9oz/255g
 3-way normally closed 10oz/284g

Agency Approvals/Compliance



2-Way Series 204 Direct Acting Valves

ENGLISH UNITS						METRIC UNITS						
Port Size NPT	Orifice Size (in.)	Cv Factor	Operating Pressure Differential (psi) Maximum			Pressure Vessel Number	Orifice Size (mm)	Kv (m³/h)	Operating Pressure Differential (bar) Maximum			Const. Ref.
			Min.	Max. AC psi	Max. DC psi				Min.	Max. AC bar	Max. DC bar	

NORMALLY CLOSED (NC)

1/8	3/64	0.06	0	950	390	20CC02EV4	1.2	0.05	0	65	27	1
1/8	1/16	0.10	0	625	255	20CC02GV4	1.6	0.09	0	43	17.5	1
1/8	5/64	0.15	0	450	180	20CC02JV4	2.0	0.13	0	31	12.5	1
1/8	3/32	0.22	0	320	130	20CC02LV4	2.4	0.19	0	22	9	1
1/8	7/64	0.28	0	245	100	20CC02MV4	2.7	0.24	0	17	7	1
1/8	1/8	0.32	0	175	60	20CC02PV4	3.2	0.28	0	12	4	1
1/8	5/32	0.38	0	100	30	20CC02QV4	4.0	0.33	0	7	2	1

NORMALLY OPEN (NO)

1/8	1/32	0.02	0	375	375	20CF02AV4	0.8	0.02	0	26	26	2
1/8	3/64	0.06	0	230	230	20CF02EV4	1.2	0.05	0	16	16	2
1/8	1/16	0.10	0	150	150	20CF02GV4	1.6	0.09	0	10	10	2
1/8	5/64	0.14	0	105	105	20CF02JV4	2.0	0.12	0	7	7	2
1/8	3/32	0.20	0	80	80	20CF02LV4	2.4	0.17	0	5.5	5.5	2

Viton™ is a Dupont Co. Trademark.

3-Way Series 304 Direct Acting Valves



Port Size NPT	ENGLISH UNITS								METRIC UNITS								Const. Ref.
	Body		Sleeve		Operating Pressure Differential (psi) Maximum			Pressure Vessel Number	Body		Sleeve		Operating Pressure Differential (bar) Maximum				
	Orifice Size (in.)	Cv Factor	Orifice Size (in.)	Cv Factor	Min.	Max. AC psi	Max. DC psi		Orifice Size (mm)	Kv (m ³ /h)	Orifice Size (mm)	Kv (m ³ /h)	Min.	Max. AC bar	Max. DC bar		

NORMALLY CLOSED (NC)

1/8	1/32	0.02	1/32	0.02	0	250	250	30CC02AV4	0.8	0.02	0.8	0.02	0	17	17	3
1/8	3/64	0.05	3/64	0.05	0	200	200	30CC02EV4	1.2	0.04	1.2	0.04	0	14	14	3
1/8	1/16	0.09	1/16	0.10	0	130	130	30CC02GV4	1.6	0.08	1.6	0.08	0	9	9	3
1/8	5/64	0.15	5/64	0.14	0	90	90	30CC02JV4	2.0	0.13	2.0	0.12	0	6	6	3
1/8	3/32	0.19	3/32	0.20	0	75	75	30CC02LV4	2.4	0.16	2.4	0.17	0	5	5	3
1/8	7/64	0.25	3/32	0.20	0	50	50	30CC02MV4	2.7	0.22	2.4	0.17	0	3.5	3.5	3
1/8	1/8	0.32	3/32	0.20	0	40	40	30CC02PV4	3.2	0.28	2.4	0.17	0	3	3	3
1/8	5/32	0.38	3/32	0.20	0	25	25	30CC02QV4	4.0	0.33	2.4	0.17	0	1.5	1.5	3

NORMALLY OPEN (NO)

1/8	1/32	0.02	1/32	0.02	0	375	375	30CF02AV4	0.8	0.02	0.8	0.02	0	26	26	3
1/8	3/64	0.05	3/64	0.05	0	230	230	30CF02EV4	1.2	0.04	1.2	0.04	0	16	16	3
1/8	1/16	0.09	1/16	0.10	0	150	150	30CF02GV4	1.6	0.08	1.6	0.08	0	10	10	3
1/8	5/64	0.15	5/64	0.14	0	105	105	30CF02JV4	2.0	0.13	2.0	0.12	0	7	7	3
1/8	3/32	0.19	3/32	0.20	0	80	80	30CF02LV4	2.4	0.16	2.4	0.17	0	5.5	5.5	3

UNIVERSAL (U)

1/8	1/32	0.02	1/32	0.02	0	200	200	30CU02AV4	0.8	0.02	0.8	0.02	0	14	14	3
1/8	3/64	0.05	3/64	0.05	0	150	150	30CU02EV4	1.2	0.05	1.2	0.04	0	10	10	3
1/8	1/16	0.09	1/16	0.10	0	100	100	30CU02GV4	1.6	0.08	1.6	0.08	0	7	7	3
1/8	5/64	0.15	5/64	0.14	0	70	70	30CU02JV4	2.0	0.13	2.0	0.12	0	5	5	3
1/8	3/32	0.19	3/32	0.20	0	50	50	30CU02LV4	2.4	0.16	2.4	0.17	0	3.5	3.5	3
1/8	7/64	0.25	3/32	0.20	0	40	40	30CU02MV4	2.7	0.22	2.4	0.17	0	3	3	3
1/8	1/8	0.32	3/32	0.20	0	30	30	30CU02PV4	3.2	0.28	2.4	0.17	0	2	2	3
1/8	5/32	0.38	3/32	0.20	0	20	20	30CU02QV4	4.0	0.33	2.4	0.17	0	1.5	1.5	3

Dimensional Drawings

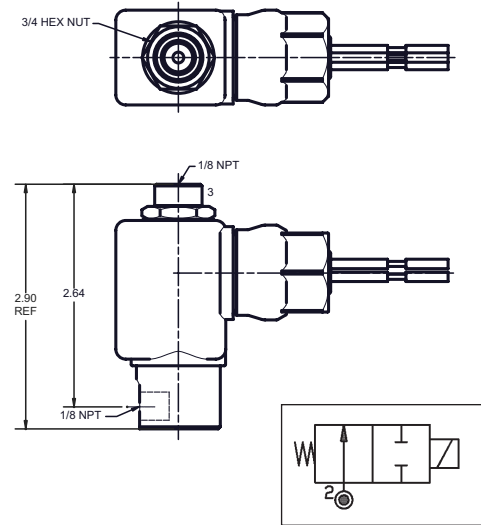
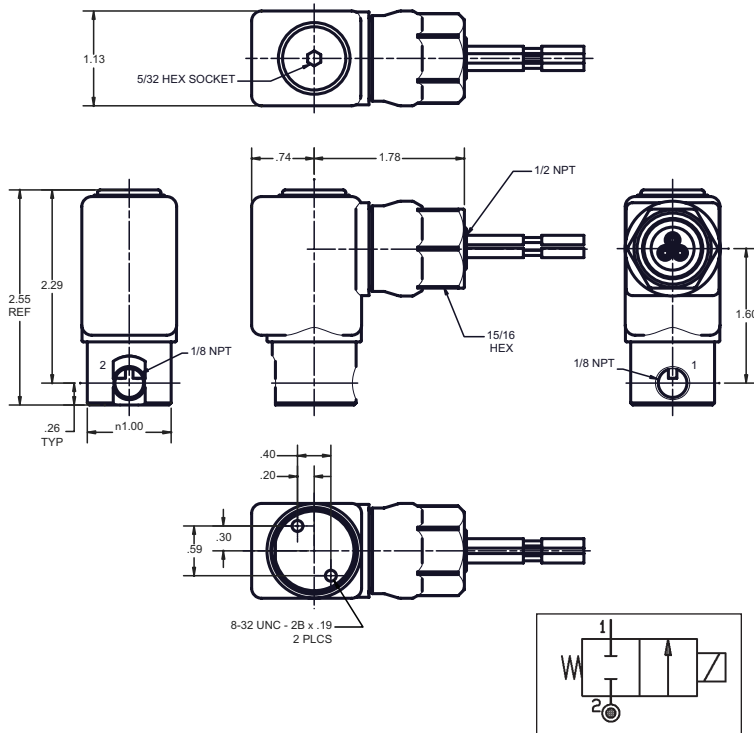

Construction Reference: 1
2-Way Normally Closed

Construction Reference: 2
2-Way Normally Open

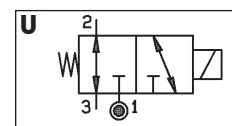
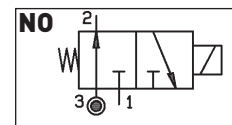
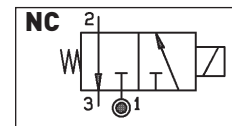
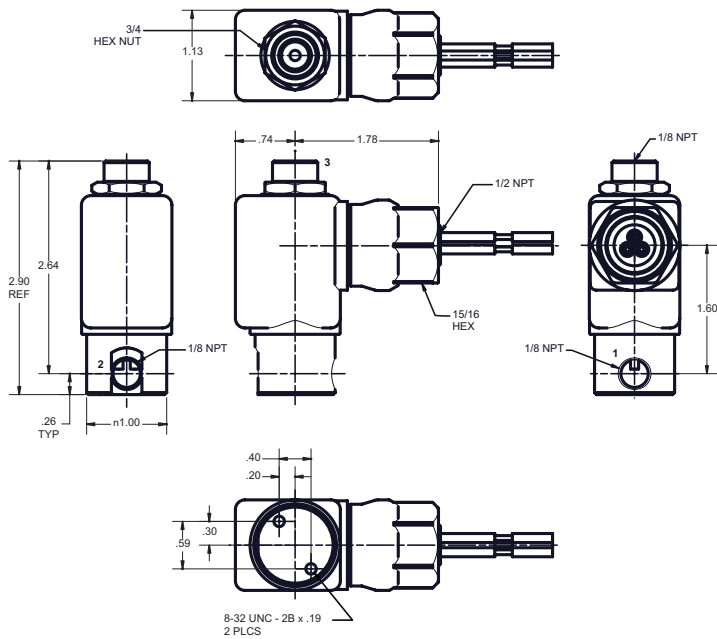

Construction Reference: 3
3-Way Normally Closed (NC), 3-Way Normally Opened (NO) and 3-Way Universal (U)

Coil Information

Encapsulated Watertight Designs. Available as Modular Coils or for Fully Assembled Valves.

Conduit Coil Coil Code: C4*



- Construction:
- Class F
 - 18" lead wires
 - Ground wire
 - 1/2" NPT conduit hub
 - NEMA 4X, IP65 protection
- AC: 10 Watts **except** 2 Way
Normally Closed is 8.5 Watts
DC: 8 Watts

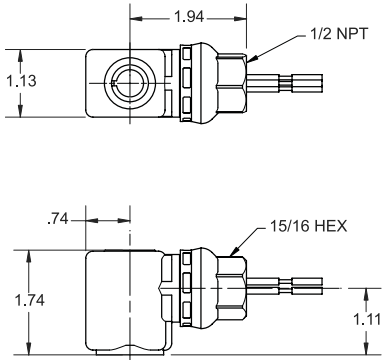

Leaded Coil Coil Code: B4*



- Construction:
- Class F
 - 18" lead wires
 - Ground wire
- AC: 10 Watts **except** 2 Way
Normally Closed is 8.5 Watts
DC: 8 Watts

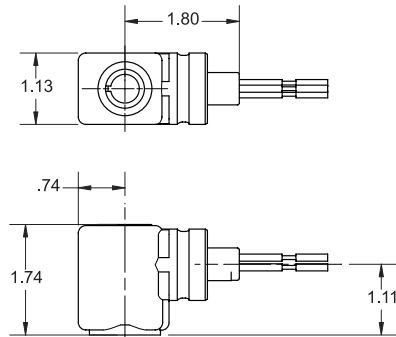

DIN Coil Coil Code: D6*



- Construction:
- Class H
 - DIN 43650A/ISO 4400 configuration
 - NEMA 4X, IP65 protection with a suitable plug and gasket
- AC: 10 Watts **except** 2 Way
Normally Closed is 8.5 Watts
DC: 8 Watts

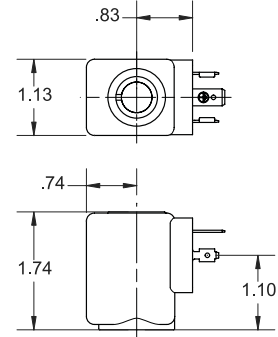

Coil Information

Conventional Coil & Enclosures for Fully Assembled Valves Only

Grommet Coil Coil Code: B2*



- Construction:
- Grommet enclosure
 - Taped wrapped coil
 - Class F
 - 18" leads- 2 wire
- AC: 7 Watts
DC: 8 Watts

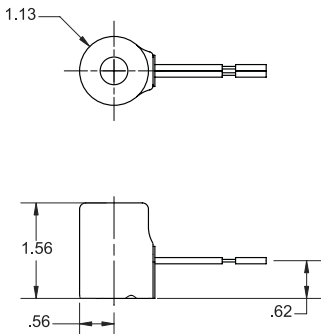

Leaded Coil Coil Code: L2*



- Construction:
- Open frame enclosure
 - Molded leaded coil
 - Class F
 - 18" leads- 2 wire
- AC: 10 Watts **except** 2 Way
Normally Closed is 8.5 Watts
DC: 8 Watts

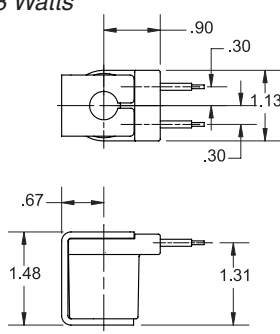

Tab Coil Coil Code: T2*



- Construction:
- Open frame enclosure
 - 1/4" tab terminals
 - Class F
- AC: 10 Watts **except** 2 Way
Normally Closed is 8.5 Watts
DC: 8 Watts

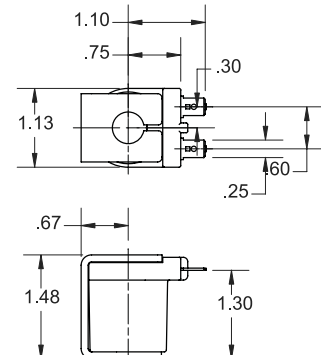

* ADD VOLTAGE CODE: A= 12VDC B= 24VDC E= 24/60 F= 120/60, 110/50 G= 240/60, 220/50

2- and 3-Way Manifold Cartridge Valves

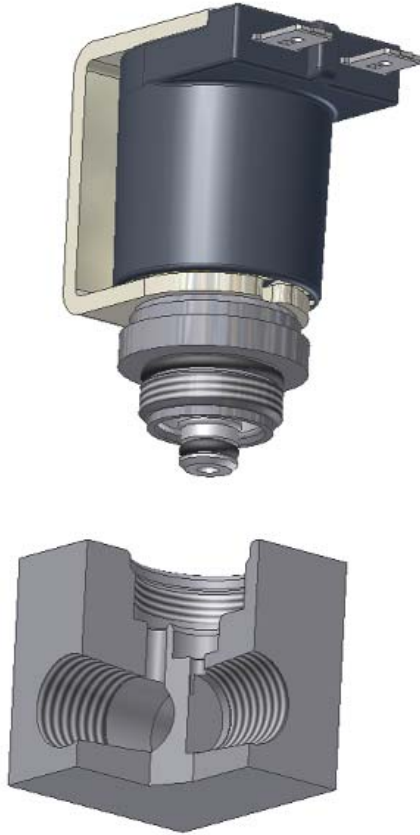

An innovative, yet simplified alternative to solenoid operators and stud mount valves.

- Space Saving Approach
- Less Manifold Machining equals Lower Manifold Cost
- No Manifold Orifices to machine or press in
- Cartridge Valves are 100% tested
- No loose parts: sleeve, plunger, spring and orifice are pressed together as one unit
- Available with all 204 304 coils

2-Way Stainless Steel Manifold Mount Cartridge Valves

ENGLISH UNITS						METRIC UNITS					
Sleeve Port Size NPT	Orifice Size (in.)	Cv	Operating Pressure Differential (psi) Maximum			Pressure Vessel Number	Orifice Size (mm)	Kv (m ³ /h)	Operating Pressure Differential (bar) Maximum		
			Min.	Max. AC psi	Max. DC psi				Min.	Max. AC bar	Max. DC bar

NORMALLY CLOSED (NC)

N/A	3/64	0.06	0	950	390	209CL5EV4	1.2	0.05	0	65	27
N/A	1/16	0.10	0	625	255	209CL5GV4	1.6	0.09	0	43	17.5
N/A	5/64	0.15	0	450	180	209CL5JV4	2.0	0.13	0	31	12.5
N/A	3/32	0.22	0	320	130	209CL5LV4	2.4	0.19	0	22	9
N/A	7/64	0.28	0	245	100	209CL5MV4	2.7	0.24	0	17	7
N/A	1/8	0.32	0	175	60	209CL5PV4	3.2	0.28	0	12	4
N/A	5/32	0.38	0	100	30	209CL5QV4	4.0	0.33	0	7	2

NORMALLY OPEN (NO)

1/8	1/32	0.02	0	375	375	209FL5AV4	0.8	0.02	0	26	26
1/8	3/64	0.06	0	230	230	209FL5EV4	1.2	0.05	0	16	16
1/8	1/16	0.10	0	150	150	209FL5GV4	1.6	0.09	0	10	10
1/8	5/64	0.13	0	105	105	209FL5JV4	2.0	0.12	0	7	7
1/8	3/32	0.17	0	80	80	209FL5LV4	2.4	0.17	0	5.5	5.5

3-Way Stainless Steel Manifold Mount Cartridge Valves



Sleeve Port Size NPT	ENGLISH UNITS								METRIC UNITS							
	Body		Sleeve		Operating Pressure Differential (psi) Maximum			Pressure Vessel Number	Body		Sleeve		Operating Pressure Differential (bar) Maximum			
	Orifice Size (in.)	Cv	Orifice Size (in.)	Cv Factor	Min.	Max. AC psi	Max. DC psi		Orifice Size (mm)	Kv (m ³ /h)	Orifice Size (mm)	Kv (m ³ /h)	Min.	Max. AC bar	Max. DC bar	

NORMALLY CLOSED (NC)

1/8	1/32	0.02	1/32	0.02	0	250	250	309CL5AV4	0.8	0.02	0.8	0.02	0	17	17
1/8	3/64	0.05	3/64	0.05	0	200	200	309CL5EV4	1.2	0.04	1.2	0.04	0	14	14
1/8	1/16	0.09	1/16	0.10	0	130	130	309CL5GV4	1.6	0.08	1.6	0.08	0	9	9
1/8	5/64	0.15	5/64	0.14	0	90	90	309CL5JV4	2.0	0.13	2.0	0.12	0	6	6
1/8	3/32	0.19	3/32	0.20	0	75	75	309CL5LV4	2.4	0.16	2.4	0.17	0	5	5
1/8	7/64	0.25	3/32	0.20	0	50	50	309CL5MV4	2.7	0.22	2.4	0.17	0	3.5	3.5
1/8	1/8	0.32	3/32	0.20	0	40	40	309CL5PV4	3.2	0.28	2.4	0.17	0	3	3
1/8	5/32	0.38	3/32	0.20	0	25	25	309CL5QV4	4.0	0.33	2.4	0.17	0	1.5	1.5

NORMALLY OPEN (NO)

1/8	1/32	0.02	1/32	0.02	0	375	375	309FL5AV4	0.8	0.02	0.8	0.02	0	26	26
1/8	3/64	0.05	3/64	0.05	0	230	230	309FL5EV4	1.2	0.04	1.2	0.04	0	16	16
1/8	1/16	0.10	1/16	0.10	0	150	150	309FL5GV4	1.6	0.08	1.6	0.08	0	10	10
1/8	5/64	0.13	5/64	0.14	0	105	105	309FL5JV4	2.0	0.13	2.0	0.12	0	7	7
1/8	3/32	0.19	3/32	0.20	0	80	80	309FL5LV4	2.7	0.16	2.4	0.17	0	5.5	5.5

UNIVERSAL (U)

1/8	1/32	0.02	1/32	0.02	0	200	200	309UL5AV4	0.8	0.02	0.8	0.02	0	14	14
1/8	3/64	0.05	3/64	0.05	0	150	150	309UL5EV4	1.2	0.04	1.2	0.04	0	10	10
1/8	1/16	0.10	1/16	0.10	0	100	100	309UL5GV4	1.6	0.08	1.6	0.08	0	7	7
1/8	5/64	0.13	5/64	0.14	0	70	70	309UL5JV4	2.0	0.13	2.0	0.12	0	5	5
1/8	3/32	0.19	3/32	0.20	0	50	50	309UL5LV4	2.4	0.16	2.4	0.17	0	3.5	3.5
1/8	7/64	0.25	3/32	0.20	0	40	40	309UL5MV4	2.7	0.22	2.4	0.17	0	3	3
1/8	1/8	0.31	3/32	0.20	0	30	30	309UL5PV4	3.2	0.28	2.4	0.17	0	2	2
1/8	5/32	0.36	3/32	0.20	0	20	20	309UL5QV4	4.0	0.33	2.4	0.17	0	1.5	1.5

Valve Numbering System



<u>1st Digit</u> Service Type	<u>2nd Digit</u> Design/Style	<u>3rd Digit</u> Body Material	<u>4th Digit</u> Function	<u>5th & 6th Digit</u> Port	<u>7th Digit</u> Body Orifice Size
2: 2-Way	0: Direct Acting	B: Brass	C: Normally Closed	02: 1/8" NPT	A: 1/32
3: 3-Way		C: 303 Stainless	F: Normally Open	L5: 3/4-24 Manifold Mount	E: 3/64
		9: Manifold Mount Cartridge	U: Universal	Cartridge	G: 1/16
				04: 1/4" NPT	J: 5/64
					L: 3/32
					M: 7/64
					P: 1/8
					Q: 5/32

<u>8th Digit</u> Main Seal Material	<u>9th Digit</u> Operator Size	<u>10th & 11th Digit</u> Coil & Enclosure	<u>12th Digit</u> Voltage	<u>13th & 14th Digit</u> Optional & Special Voltage
V: FKM- Viton™ Fluoroelastomer	4: 0.442 Dia.	1.125" Integrated Modular Coils	A: 12VDC	Consult Factory
E: EPDM		B4: Integrated, class F, 18" leads, 3-wire	B: 24VDC	
N: Nitrile NBR		B5: Integrated, class H, 18" leads, 3-wire	E: 24/60	
T: Teflon™		C4: Integrated, 1/2" Conduit, class F, 18" leads, 3-wire	F: 120/60; 110/50	
C: Neoprene		C5: Integrated, 1/2" Conduit, class H, 18" leads, 3-wire	G: 240/60; 220/50	
		D6: Integrated, DIN 43650A class H		
		1.125" Standard Coils		
		B2: Leaded with metal enclosure, class F, 18" leads		
		L2: Molded leaded coil with Yoke, class F, 18" leads		
		T2: Molded 1/4" tab with Yoke, class F,		

Note: The table provided is to interpret product specifications. It should not be used to create a valve number.

Viton™ is a Dupont Co. Trademark.

Teflon™ is a Dupont Co. Trademark.

Electrical Data



To determine the approximate Holding or Inrush Current for AC voltages including 24/60, 120/60 and 240/60 in amperes, divide the voltage into the VA rating indicated in the AC Power Consumption tables. DC valves have no inrush current. The current rating in amperes are shown in the DC table. Figures are based on nominal values and will vary slightly depending on operating voltage and coil tolerances.

AC Consumption Ratings

Valve Type	VA Holding	VA Inrush
2-Way Normally Closed	13	28
2-Way Normally Open	17	25
3-Way Valves	17	25

DC Current Consumption Ratings

Coil Type	12 VDC	24 VDC
8 Watt	0.67	0.33

Electrical Specifications

These Series 204 and 304 solenoid valves use coil designs that are interchangeable on all valve bodies. They are available in a wide variety of standard voltages and frequencies. The modular coils are labeled with coil code and voltage providing easy identification.

Construction

Encapsulated watertight coils are standard for all modular valves listed in the catalog. The special compound is waterproof and impervious to oil, dust and most corrosive fumes and vapors.

All coils are Class "F" or "H" (optional) rated for high temperature application requirements. The coils are constructed in accordance with UL, NEMA, and other accepted standards.

Coil Temperature Ratings

Coils are rated by temperature classes that correspond to a maximum allowable coil temperature. The maximum coil temperature is the temperature to which the coil can be exposed without experiencing thermal degradation of the magnet wire insulation. These classes and corresponding maximum temperature levels are:

Class	Nominal Class Temperature	Permissible Temp. by Change of Resistance Method (UL)	Temp. Rise Above 25°C (77°F) Ambient Temp.
F	155°C (311°F)	140°C (284°F)	115°C (207°F)
H	180°C (356°F)	160°C (320°F)	135°C (243°F)

Optional Selections



Additional features may be desired to either enhance or simplify the end user's utilization and/or installation of the Series 204 and 304 Solenoid Valves. The following are examples of features that can be considered. We will be happy to review the feasibility of each application. Please contact Parker Hannifin Fluid Control Division at 860-827-2300 for assistance.

Seal Materials:

- Buna-N, Nitrile
- Ethylene Propylene
- Neoprene
- Teflon™

Teflon™ is a Dupont Co. trademark

Body Construction

- Alternate Materials
- Manifolds
- Port connection location, size, type

Flow Control

- Metering

Service Needs

- Cleaning for Oxygen Service
- Instrumentation Cleaning

Electrical

- Class H (180°C)
- Reduced Wattage
- Lead Wire terminations/connectors

Food Grade Service

- NSF Standard 61 certification



1/4" NPT Porting Option

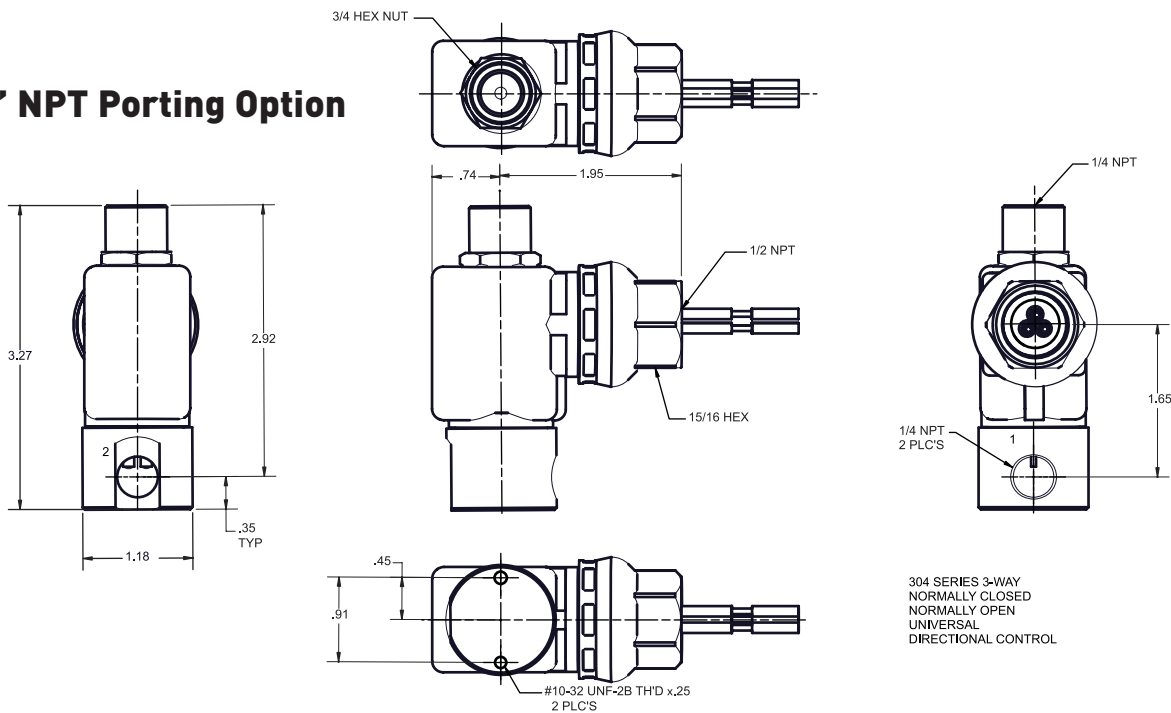

Accessories





Mounting Bracket

A universal stainless steel mounting bracket for the 1/8" NPT valves may be ordered separately. The mounting bracket can be assembled to the valve body utilizing the body mounting holes.

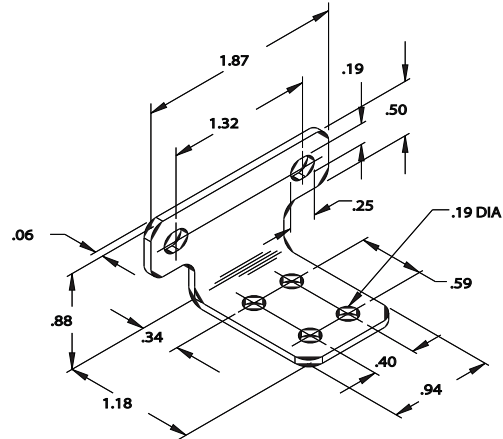
**Part Number:
4K007**



DIN Coil Options

	Description	Part Number
	Cable Gland DIN Plug *	ELECD1
	1/2" Conduit DIN Plug *	ELECD2

* The plug comes complete with gasket to meet NEMA 4 specification. DIN coil options available separately.

Offer Of Sale

The items described in this document are hereby offered for sale at prices to be established by Parker Hannifin Corporation, its subsidiaries and its authorized distributors. This offer and its acceptance by any customer ("Buyer") shall be governed by all of the following Terms and Conditions. Buyer's order for any item described in its document, when communicated to Parker Hannifin Corporation, its subsidiary or an authorized distributor ("Seller") verbally or in writing, shall constitute acceptance of this offer.

1. Terms and Conditions of Sale: All descriptions, quotations, proposals, offers, acknowledgments, acceptances and sales of Seller's products are subject to and shall be governed exclusively by the terms and conditions stated herein. Buyer's acceptance of any offer to sell is limited to these terms and conditions. Any terms or conditions in addition to, or inconsistent with those stated herein, proposed by Buyer in any acceptance of an offer by Seller, are hereby objected to. No such additional, different or inconsistent terms and conditions shall become part of the contract between Buyer and Seller unless expressly accepted in writing by Seller. Seller's acceptance of any offer to purchase by Buyer is expressly conditional upon Buyer's assent to all the terms and conditions stated herein, including any terms in addition to, or inconsistent with those contained in Buyer's offer. Acceptance of Seller's products shall in all events constitute such assent.

2. Payment: Payment shall be made by Buyer net 30 days from the date of delivery of the items purchased hereunder. Any claims by Buyer for omissions or shortages in a shipment shall be waived unless Seller receives notice thereof within 30 days after Buyer's receipt of the shipment. The minimum order amount is \$125.00 net, unless otherwise noted on the quotation.

3. Delivery: Unless otherwise provided on the face hereof, delivery shall be made F.O.B. Seller's plant. Regardless of the method of delivery, however, risk of loss shall pass to Buyer upon Seller's delivery to a carrier. Any delivery dates shown are approximate only and Seller shall have no liability for any delays in delivery. Shipments are made by common carrier. Any premium freight must be requested and paid for by the Buyer.

4. Warranty: Seller warrants that the items sold hereunder shall be free from defects in material or workmanship for a period of 2 years from the date of shipment to Buyer, or 2,000 hours of use, whichever expires first. Exception to this is the Angle Body Valve line has a 1 year warranty. THIS WARRANTY COMPRISES THE SOLE AND ENTIRE WARRANTY PERTAINING TO ITEMS PROVIDED HEREUNDER. SELLER MAKES NO OTHER WARRANTY, GUARANTEE, OR REPRESENTATION OF ANY KIND WHATSOEVER. ALL OTHER WARRANTIES, INCLUDING BUT NOT LIMITED TO, MERCHANTABILITY AND FITNESS FOR PURPOSE, WHETHER EXPRESS, IMPLIED, OR ARISING BY OPERATION OF LAW, TRADE USAGE, OR COURSE OF DEALING ARE HEREBY DISCLAIMED. NOTWITHSTANDING THE FOREGOING, THERE ARE NO WARRANTIES WHATSOEVER ON ITEMS BUILT OR ACQUIRED WHOLLY OR PARTIALLY, TO BUYER'S DESIGNS OR SPECIFICATIONS.

5. Limitation Of Remedy: SELLER'S LIABILITY ARISING FROM OR IN ANY WAY CONNECTED WITH THE ITEMS SOLD OR THIS CONTRACT SHALL BE LIMITED EXCLUSIVELY TO REPAIR OR REPLACEMENT OF THE ITEMS SOLD OR REFUND OF THE PURCHASE PRICE PAID BY BUYER, AT SELLER'S SOLE OPTION. IN NO EVENT SHALL SELLER BE LIABLE FOR ANY INCIDENTAL, CONSEQUENTIAL OR SPECIAL DAMAGES OF ANY KIND OR NATURE WHATSOEVER, INCLUDING BUT NOT LIMITED TO LOST PROFITS ARISING FROM OR IN ANY WAY CONNECTED WITH THIS AGREEMENT OR ITEMS SOLD HEREUNDER, WHETHER ALLEGED TO ARISE FROM BREACH OF CONTRACT, EXPRESS OR IMPLIED WARRANTY, OR IN TORT, INCLUDING WITHOUT LIMITATION, NEGLIGENCE, FAILURE TO WARN OR STRICT LIABILITY.

6. Changes, Reschedules and Cancellations: Buyer may request to modify the designs or specifications for the items sold hereunder as well as the quantities and delivery dates thereof, or may request to cancel all or part of this order, however, no such requested modification or cancellation shall become part of the contract between Buyer and Seller unless accepted by Seller in a written amendment to this Agreement. Acceptance of any such requested modification or cancellation shall be at Seller's discretion, and shall be upon such terms and conditions as Seller may require.

7. Special Tooling: A tooling charge may be imposed for any special tooling, including without limitation, dies, fixtures, molds and patterns, acquired to manufacture items sold pursuant to this contract. Such special tooling shall be and remain Seller's property notwithstanding payment of any charges by Buyer. In no event will Buyer acquire any interest in apparatus belonging to Seller which is utilized in the manufacture of the items sold hereunder, even if such apparatus has been specially converted or adapted for such manufacture and notwithstanding any charges paid by Buyer. Unless otherwise agreed, Seller shall have the right to alter, discard or otherwise dispose of any special tooling or other property in its

sole discretion at any time.

8. Buyer's Property: Any designs, tools, patterns, materials, drawings, confidential information or equipment furnished by Buyer or any other items which become Buyer's property, may be considered obsolete and may be destroyed by Seller after two (2) consecutive years have elapsed without Buyer placing an order for the items which are manufactured using such property. Seller shall not be responsible for any loss or damage to such property while it is in Seller's possession or control.

9. Taxes: Unless otherwise indicated on the face hereof, all prices and charges are exclusive of excise, sales, use, property, occupational or like taxes which may be imposed by any taxing authority upon the manufacture, sale or delivery of the items sold hereunder. If any such taxes must be paid by Seller or if Seller is liable for the collection of such tax, the amount thereof shall be in addition to the amounts for the items sold. Buyer agrees to pay all such taxes or to reimburse Seller therefore upon receipt of its invoice. If Buyer claims exemption from any sales, use or other tax imposed by any taxing authority, Buyer shall save Seller harmless from and against any such tax, together with any interest or penalties thereon which may be assessed if the items are held to be taxable.

10. Indemnity For Infringement of Intellectual Property Rights: Seller shall have no liability for infringement of any patents, trademarks, copyrights, trade dress, trade secrets or similar rights except as provided in this Part 10. Seller will defend and indemnify Buyer against allegations of infringement of U.S. patents, U.S. trademarks, copyrights, trade dress and trade secrets (hereinafter 'Intellectual Property Rights'). Seller will defend at its expense and will pay the cost of any settlement or damages awarded in an action brought against Buyer based on an allegation that an item sold pursuant to this contract infringes the Intellectual Property Rights of a third party. Seller's obligation to defend and indemnify Buyer is contingent on Buyer notifying Seller within ten (10) days after Buyer becomes aware of such allegations of infringement, and Seller having sole control over the defense of any allegations or actions including all negotiations for settlement or compromise. If an item sold hereunder is subject to a claim that it infringes the Intellectual Property Rights of a third party, Seller may, at its sole expense and option, procure for Buyer the right to continue using said item, replace or modify said item so as to make it noninfringing, or offer to accept return of said item and return the purchase price less a reasonable allowance for depreciation. Notwithstanding the foregoing, Seller shall have no liability for claims of infringement based on information provided by Buyer, or directed to items delivered hereunder for which the designs are specified in whole or part by Buyer, or infringements resulting from the modification, combination or use in a system of any item sold hereunder. The foregoing provisions of this Part 10 shall constitute Seller's sole and exclusive liability and Buyer's sole and exclusive remedy for infringement of Intellectual Property Rights. If a claim is based on information provided by Buyer or if the design for an item delivered hereunder is specified in whole or in part by Buyer, Buyer shall defend and indemnify Seller for all costs, expenses or judgments resulting from any claim that such item infringes any patent, trademark, copyright, trade dress, trade secret or any similar right.

11. Force Majeure: Seller does not assume the risk of and shall not be liable for delay or failure to perform any of Seller's obligations by reason of circumstances beyond the reasonable control of Seller (hereinafter 'events of Force Majeure'). Events of Force Majeure shall include without limitation, accidents, acts of God, strikes or labor disputes, acts, laws, rules or regulations of any government or government agency, fires, floods, delays or failures in delivery of carriers or suppliers, shortages of materials and any other cause beyond Seller's control.

12. Entire Agreement/Governing Law: The terms and conditions set forth herein, together with any amendments, modifications and any different terms or conditions expressly accepted by Seller in writing, shall constitute the entire Agreement concerning the items sold, and there are no oral or other representations or agreements which pertain thereto. This Agreement shall be governed in all respects by the law of the State of Ohio. No actions arising out of the sale of the items sold hereunder or this Agreement may be brought by either party more than two (2) years after the cause of action accrues.



Catalog 204304S0407
April 2007

Parker Hannifin Corporation

Fluid Control Division
95 Edgewood Avenue
New Britain, CT 06051
Tel. (860) 827-2300 Fax (860) 827-2384
www.parker.com/fcd

Coil Options for Modular Ordering

Conduit Coil



Coil Code: C4

DIN Coil



Coil Code: D6

Leaded Coil



Coil Code: B4

Standard Voltages and Codes: Add Standard voltage code to end of coil code.

Voltage Code	DC Voltage	AC Voltage
A	12 VDC	
B	24 VDC	
E		24/60
F		120/60; 110/50
G		240/60; 220/50

Need more information...

Visit our website

@ www.parker.com/fcd

Or

**Call Catalog Services to order the
Skinner Valve™ Catalog (CFL00897),
Gold Ring™ Catalog (7300AC) and
Valve Actuation Catalog (VAP0495).**

Tel: 440-205-7799

e-mail: catalogs@parker.com

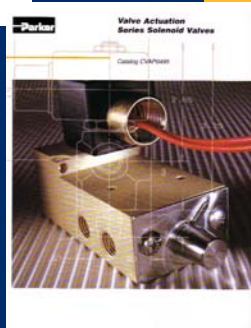
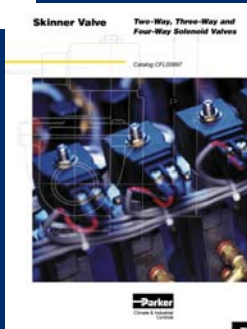

**Fold out to reveal
Coil Chart**