

Skinner Valve™ and Gold Ring™ Products

*process
control*

*beverage
dispensing*

*industrial
equipment*

*car wash
industry*

*sterilizer
industry*



*laundry
equipment*

*medical &
instrumentation*

*mobile &
HVAC*

*cooking
industry*



24 hours



Parker is able to make this a reality. PHConnect.com gives you the ability to be plugged into Parker 24 hours 7 days a week.

The Skinner Valve™ and Gold Ring™ products featured in this catalog ship within 24 to 48 hours 5 days a week, upon order placement.



7 days a week

The solenoid coil and pressure vessel are boxed and shipped separately. Orders of 50 pieces or less ship within 24 hours. Quantities greater than 50 pieces will ship in five working days.

24/7

TABLE OF CONTENTS

How to Use this Catalog.....	1-2
2 Way Section.....	3-9
2 Way Normally Closed Direct Acting.....	3-4
2 Way Normally Open Direct Acting.....	5
2 Way Normally Closed Pilot-Operated.....	6-7
2 Way Normally Open Pilot-Operated.....	8
2 Way Normally Closed Steam and Hot Water.....	9
3 Way Section.....	10-13
3 Way Normally Closed Direct Acting.....	10
3 Way Normally Open Direct Acting.....	11
3 Way Multipurpose Direct Acting.....	12
3 Way Normally Closed Pilot-Operated.....	13
4 Way Section.....	14-15
4 Way Single Solenoid Direct Acting.....	14
4 Way Single Solenoid Pilot-Operated.....	15
Angle Body Valves	16-17
Offer of Sale.....	18-19
Coils.....	Open Back Cover

For complete valve specifications including materials of construction, consult Gold Ring™ catalog 7300AC, VAP0495 and Skinner Valve™ catalog CFL00897.

HOW TO USE THE NEW 24/7 CATALOG

Modularity: Our solenoid valves come in two parts: pressure vessel and solenoid coil.

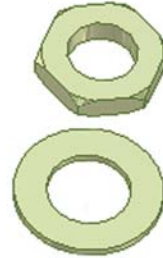

Voltages
24/60
120/60, 110/50
240/60, 220/50
12VDC
24VDC

DIN Coil or 1/2" NPT Conduit Coil

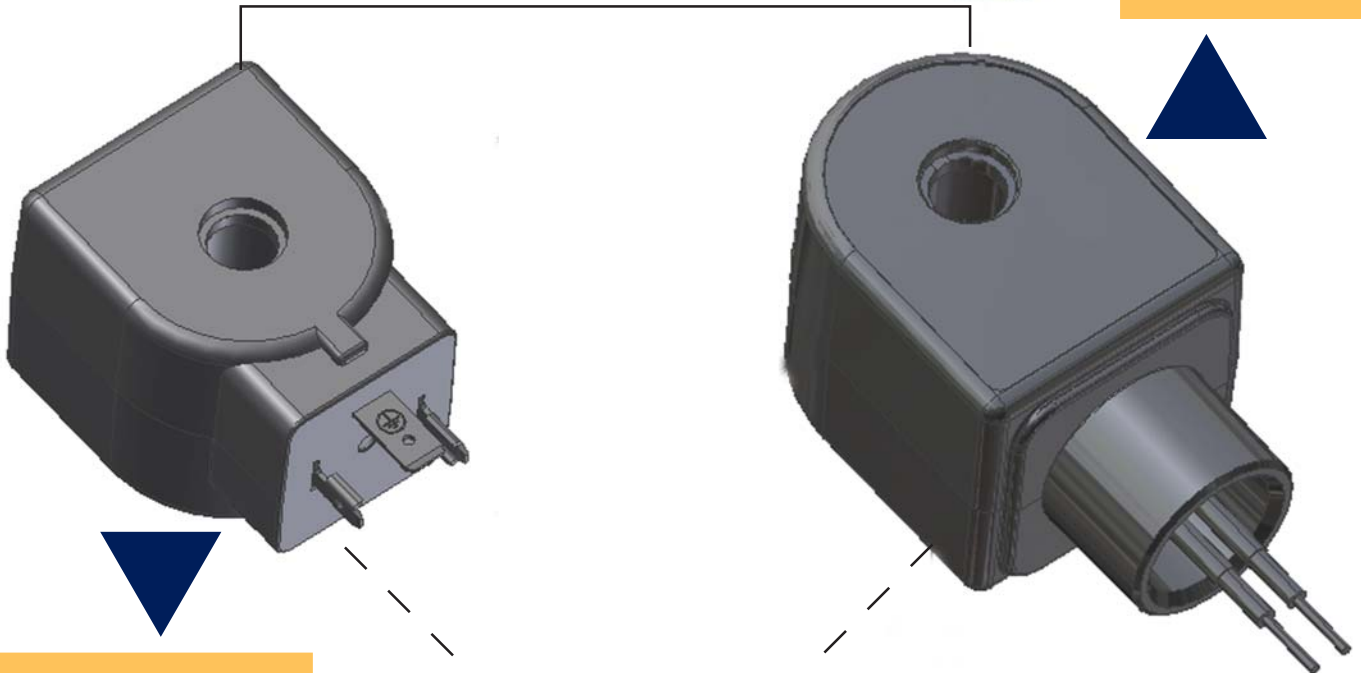

Voltages
24/60
120/60, 110/50
240/60, 220/50
12VDC
24VDC

The New standard.

Parker Gold Ring™ and Skinner Valve™ lines offer an industry unique inventory saving value. With modularity, order a pressure vessel and mix and match the coils to make endless product capabilities.

Coils will carry **cULus** recognition.

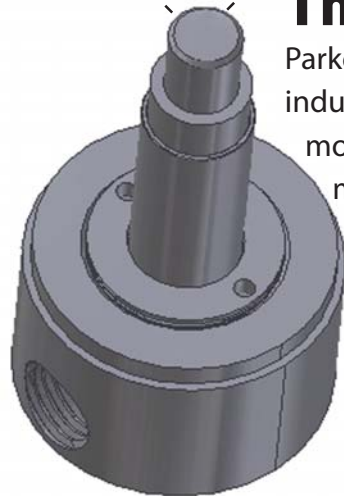

Navigation: 4 Easy Steps

This new catalog combines Skinner Valve™ and Gold Ring™ products into one! The 24/7 catalog allows you to browse the Product Class One products, that ship within 24 to 48 hours.

2-WAY

2 Way Normally Closed Direct Acting

BRASS

Part No.	Part Name	Coil Voltage	Coil Wattage	Coil Pressure	Coil Temp	Coil Material	Coil Style	Coil Qty	Coil Part No.	Coil Part Name	Coil Part Description	Coil Part Qty
108	108	24	0	200	200	100	10	PCPF	712308N000	712308N000	0	
108	108	24	0	200	200	100	10	PCPF	712308N000	712308N000	0	
108	108	24	0	100	100	100	10	PFM	712308N000	712308N000	0	
108	108	24	0	100	100	100	10	PFM	712308N000	712308N000	0	

1 **2**

2-WAY

2 Way Normally Closed Direct Acting

STAINLESS STEEL

Part No.	Part Name	Coil Voltage	Coil Wattage	Coil Pressure	Coil Temp	Coil Material	Coil Style	Coil Qty	Coil Part No.	Coil Part Name	Coil Part Description	Coil Part Qty
108	108	24	0	200	200	100	10	PCPF	712308N000	712308N000	0	
108	108	24	0	200	200	100	10	PCPF	712308N000	712308N000	0	
108	108	24	0	100	100	100	10	PFM	712308N000	712308N000	0	
108	108	24	0	100	100	100	10	PFM	712308N000	712308N000	0	

Coils **3**

Please refer to the chart number reference within the catalog to find the 24/7 coils available for 24 to 48 hour delivery.

Charting™	Watts	1/2" NPT Coils*	3/4" NPT Coils*
CHART 1 10 watts, Class F	2400 11800, 12800 20800, 24800	APFC01 AF4005 APFC15	APP001 APP005 APP015
CHART 2 15 watts, Class F	2400 11800, 12800 20800, 24800	CP4001 CP4005 CP4015	CPN001 CPN005 CPN015
CHART 3 15 watts, Class F	12000 24000	3P4001 3P4005	3P0001 3P0005
CHART 4 30 watts, Class F	2400 11800, 12800 20800, 24800	CP4001 CP4005 CP4015	CPN001 CPN005 CPN015
CHART 5 30 watts, Class F	2400 11800, 12800 20800, 24800	C11001 C11005 C11015	C1N001 C1N005 C1N015
CHART 6 30 watts, Class F	2400 11800, 12800 20800, 24800	C22001 C22005 C22015	C2N001 C2N005 C2N015
CHART 7 30 watts, Class F	2400 11800, 12800 20800, 24800	C33001 C33005 C33015	C3N001 C3N005 C3N015

The solenoid coil and pressure vessel are boxed and shipped separately. Orders of 50 pieces or less ship within 24 hours. Quantities greater than 50 pieces will ship in five working days.

- 1 Choose your pressure vessel
- 2 Choose your coil reference number from the coil chart.
- 3 Find your coil reference number on the Coil Chart
- 4 Place order for pressure vessel and coil as separate items

Flip out the tab attached to the back cover to reveal the Coil Chart.

Images shown in this catalog are representative only. The stated wattage represents a nominal value. The actual wattage may vary depending on coil/pressure vessel selection.



2 Way Normally Closed Direct Acting



BRASS

2 WAY

Pipe Size (NPT)	Orifice Size (Inches)	Cv Flow Factor	Min	Max. Pressure Differential			Max. Media Temp. °F	Watt	Seal	Pressure Vessel Catalog Number	Coil Chart
				Air, Inert Gas (PSI)	Water (PSI)	Lt. Oil 300 SSU (PSI)					
AC Voltage											
1/8	1/8	.31	0	365	365	365	165	10	PCTFE	7121KBN1NF00	5
1/4	1/8	.31	0	365	365	365	165	10	PCTFE	7121KBN2NF00	5
1/4	1/8	.31	0	145	145	145	185	10	FKM	7121KBN2NV00	5
1/4	5/32	.52	0	120	120	120	185	10	FKM	7121KBN2QV00	5
1/4	13/64	.76	0	80	80	80	185	10	FKM	7121KBN2SV00	5
DC Voltage											
1/8	1/8	.31	0	125	125	125	165	10	PCTFE	7121KBN1NF00	5
1/4	1/8	.31	0	125	125	125	165	10	PCTFE	7121KBN2NF00	5
1/4	1/8	.31	0	125	125	125	185	10	FKM	7121KBN2NV00	5
1/4	5/32	.52	0	60	60	60	185	10	FKM	7121KBN2QV00	5
1/4	13/64	.76	0	30	30	30	185	10	FKM	7121KBN2SV00	5

Parker 2 Way Normally Closed Direct Acting



STAINLESS STEEL

2 WAY

Pipe Size (NPT)	Orifice Size (Inches)	Cv Flow Factor	Min	Max. Pressure Differential			Max. Media Temp. °F	Watt	Seal	Pressure Vessel Catalog Number	Coil Chart
				Air, Inert Gas (PSI)	Water (PSI)	Lt. Oil 300 SSU (PSI)					
AC Voltage											
1/8	1/16	.07	0	1250	1250	1250	185	10	Nylon	71216SN1GL00	5
1/8	3/32	.18	0	275	275	275	185	10	NBR	71215SN1KN00	5
1/8	1/8	.28	0	200	200	200	185	10	NBR	71215SN1MN00	5
1/4	1/32	.02	0	3000	3000	3000	185	10	Nylon	71216SN2BL00	5
1/4	3/64	.06	0	450	450	450	185	10	NBR	71215SN2EN00	5
1/4	3/64	.037	0	1500	1500	1500	185	10	PTFE	71216SN2FU00	5
1/4	1/16	.10	0	350	350	350	185	10	NBR	71215SN2GN00	5
1/4	3/32	.18	0	275	275	275	185	10	NBR	71215SN2KN00	5
1/4	1/8	.28	0	200	200	200	185	10	NBR	71215SN2MN00	5
1/4	5/32	.40	0	110	110	110	185	10	NBR	71215SN2QN00	5
1/4	3/16	.50	0	80	80	80	185	10	NBR	71215SN2SN00	5
1/4	1/4	.75	0	40	40	40	185	10	NBR	71215SN2VN00	5
1/4	5/16	1.1	0	20	20	20	185	10	NBR	71215SN21N00	5
3/8	9/32	.85	0	90	80	80	200	16	NBR	06F20C6118BDF	4
3/8	3/8	2.0	5	11	11	11	185	10	NBR	71215SN33NHP	5
3/8	3/8	2.0	0	6	6	6	185	10	NBR	71215SN33N00	5
DC Voltage											
1/8	1/16	.07	0	500	500	500	185	10	Nylon	71216SN1GL00	5
1/8	1/16	.07	0	1000	1000	1000	185	22	Nylon	71216SN1GL00	7
1/8	3/32	.18	0	275	275	275	185	10	NBR	71215SN1KN00	5
1/8	1/8	.28	0	150	150	150	185	10	NBR	71215SN1MN00	5
1/4	3/64	.06	0	450	450	450	185	10	NBR	71215SN2EN00	5
1/4	1/32	.02	0	2500	2500	2500	185	10	Nylon	71216SN2BL00	5
1/4	1/32	.02	0	3000	3000	3000	185	22	Nylon	71216SN2BL00	7
1/4	3/64	.037	0	1000	1000	1000	185	10	PTFE	71216SN2FU00	5
1/4	3/64	.037	0	1500	1500	1500	185	22	PTFE	71216SN2FU00	7
1/4	1/16	.10	0	350	350	350	185	10	NBR	71215SN2GN00	5
1/4	3/32	.18	0	275	275	275	185	10	NBR	71215SN2KN00	5
1/4	1/8	.28	0	150	150	150	185	10	NBR	71215SN2MN00	5
1/4	5/32	.40	0	60	60	60	185	10	NBR	71215SN2QN00	5
1/4	3/16	.50	0	25	25	25	185	10	NBR	71215SN2SN00	5
1/4	1/4	.75	0	10	10	10	185	10	NBR	71215SN2VN00	5
1/4	5/16	1.1	0	3	3	3	185	10	NBR	71215SN21N00	5
3/8	3/8	2.0	0	5	5	5	185	22	NBR	71215SN33N00	7



2 Way Normally Open Direct Acting

2 WAY



BRASS

Pipe Size (NPT)	Orifice Size (Inches)	Cv Flow Factor	Min	Max. Pressure Differential			Max. Media Temp. °F	Watt	Seal	Pressure Vessel Catalog Number	Coil Chart
				Air, Inert Gas (PSI)	Water (PSI)	Lt. Oil 300 SSU (PSI)					
AC Voltage											
1/4	3/32	.17	0	300	250	230	180	11	NBR	04F20O1106ACF	2
1/4	1/8	.35	0	130	110	100	180	11	NBR	04F20O1108ACF	2
1/4	9/32	.96	0	30	25	20	180	11	NBR	04F20O2118ACF	2
1/2	7/16	2.8	0	15	15	-	200	16	NBR	08F20O2128ADF	4



STAINLESS STEEL

Pipe Size (NPT)	Orifice Size (Inches)	Cv Flow Factor	Min	Max. Pressure Differential			Max. Media Temp. °F	Watt	Seal	Pressure Vessel Catalog Number	Coil Chart
				Air, Inert Gas (PSI)	Water (PSI)	Lt. Oil 300 SSU (PSI)					
AC Voltage											
1/4	3/32	.15	0	250	250	250	185	10	NBR	71295SN2KNJ1	5
DC Voltage											
1/4	3/32	.15	0	250	250	250	185	10	NBR	71295SN2KNJ1	5



2 Way Normally Closed Pilot Operated



BRASS

2 WAY

Pipe Size (NPT)	Orifice Size (Inches)	Cv Flow Factor	Min	Max. Pressure Differential			Max. Media Temp. °F	Watt	Seal	Pressure Vessel Catalog Number	Coil Chart
				Air, Inert Gas (PSI)	Water (PSI)	Lt. Oil 300 SSU (PSI)					
AC Voltage											
1/4	11/32	1.2	5	300	300	300	180	6	NBR	04F25C2122CAF	1
1/4	1/4	.76	5	1500	1500	1500	210	10	PTFE	73216BN2MT00	5
1/4	7/16	2.0	3	150	150	150	185	10	NBR	7321KBN2RN00	5
3/8	7/16	2.5	3	150	150	150	185	10	NBR	7321KBN3SN00	5
3/8	1/2	2.4	5	300	300	300	185	10	NBR	73212BN3SN00	5
3/8	5/8	3	5	200	135	135	180	6	NBR	06F22C2140AAF	1
3/8	5/8	4.0	0	150	150	150	180	11	NBR	06F23C2140ACF	2
1/2	1/2	2.8	5	300	300	300	185	10	NBR	73212BN4TN00	5
1/2	5/8	4.0	5	200	135	135	180	6	NBR	08F22C2140AAF	1
1/2	5/8	4.0	5	300	300	300	175	16	NBR	08F22C2140ADF	4
1/2	5/8	4.0	0	100	100	100	185	10	NBR	72218BN4UN00	5
1/2	5/8	4.0	5	150	150	150	185	10	NBR	73218BN4UN00	5
1/2	5/8	4.0	0	150	150	150	180	11	NBR	08F23C2140ACF	2
3/4	3/4	5.0	0	100	100	100	185	10	NBR	72218BN5VN00	5
3/4	3/4	5.0	5	125	125	125	180	6	NBR	12F22C2148AAF	1
3/4	3/4	5.0	5	150	150	150	185	10	NBR	73218BN5VN00	5
3/4	3/4	6.5	5	250	150	100	180	6	NBR	12F24C2148AAF	1
3/4	3/4	7.3	5	300	300	300	185	10	NBR	73212BN52N00	5
3/4	3/4	5.0	5	150	150	150	180	11	NBR	12F23C2148ACF	2
1	1	13	5	150	150	100	180	6	NBR	16F24C2164AAF	1
1	1	11.7	0	230	230	230	185	10	NBR	7221GBN64N00	5
1	1	11.0	5	300	300	300	185	10	NBR	73212BN63N00	5
1	1 1/16	13.5	5	125	125	125	185	10	NBR	73218BN64N00	5
1 1/4	1 1/8	15.0	5	150	125	100	180	6	NBR	20F24C2172AAF	1
1 1/2	1 1/4	22.5	5	150	125	100	180	6	NBR	24F24C2180AAF	1
2	1 9/16	38.6	5	230	230	230	185	10	NBR	7321GBN99N00	5



2 Way Normally Closed Pilot Operated



STAINLESS STEEL

Pipe Size (NPT)	Orifice Size (Inches)	Cv Flow Factor	Min	Max. Pressure Differential			Max. Media Temp. °F	Watt	Seal	Pressure Vessel Catalog Number	Coil Chart
				Air, Inert Gas (PSI)	Water (PSI)	Lt. Oil 300 SSU (PSI)					

AC Voltage

3/8	5/8	3.0	0	150	150	150	180	11	NBR	06F23C6140ACF	2
1/2	1/2	4.0	0	150	150	150	180	11	NBR	08F23C6140ACF	2
3/4	3/4	5.0	0	150	150	150	180	11	NBR	12F23C6148ACF	2



BRASS

Pipe Size (NPT)	Orifice Size (Inches)	Cv Flow Factor	Min	Max. Pressure Differential			Max. Media Temp. °F	Watt	Seal	Pressure Vessel Catalog Number	Coil Chart
				Air, Inert Gas (PSI)	Water (PSI)	Lt. Oil 300 SSU (PSI)					

DC Voltage

1/4	1/4	.76	5	800	800	800	210	10	PTFE	73216BN2MT00	5
1/4	7/16	2.0	3	60	60	60	185	10	NBR	7321KBN2RN00	5
1/4	11/32	1.2	5	275	275	275	150	11.5	NBR	04F25C2122C3F	3
3/8	7/16	2.5	3	60	60	60	185	10	NBR	7321KBN3SN00	5
3/8	1/2	2.4	5	300	300	300	185	10	NBR	73212BN3SN00	5
3/8	5/8	3.0	5	100	100	100	150	11.5	NBR	06F22C2140A3F	3
1/2	5/8	4.0	0	40	40	40	185	22	NBR	72218BN4UN00	7
1/2	5/8	4.0	5	150	150	150	185	10	NBR	73218BN4UN00	5
1/2	1/2	2.8	5	300	300	300	185	10	NBR	73212BN4TN00	5
3/4	3/4	5.0	5	90	90	75	150	11.5	NBR	12F22C2148A3F	3
3/4	3/4	5.0	0	40	40	40	185	22	NBR	72218BN5VN00	7
3/4	3/4	5.0	5	150	150	150	185	10	NBR	73218BN5VN00	5
3/4	3/4	7.3	5	300	300	300	185	10	NBR	73212BN52N00	5
1	1	13.0	5	125	125	125	150	11.5	NBR	16F24C2164A3F	3
1	1	11.7	0	85	85	85	185	22	NBR	7221GBN64N00	7
1	1	11.0	5	300	300	300	185	10	NBR	73212BN63N00	5
1	1 1/16	13.5	5	125	125	125	185	10	NBR	73218BN64N00	5
1 1/4	1 1/8	15.0	5	125	125	125	150	11.5	NBR	20F24C2172A3F	3



2 Way Normally Open Pilot Operated



BRASS

Pipe Size (NPT)	Orifice Size (Inches)	Cv Flow Factor	Min	Max. Pressure Differential			Max. Media Temp. °F	Watt	Seal	Pressure Vessel Catalog Number	Coil Chart
				Air, Inert Gas (PSI)	Water (PSI)	Lt. Oil 300 SSU (PSI)					
AC Voltage											
3/8	5/8	3.0	0	150	150	150	180	11	NBR	06F23O2140ACF	2
1/2	5/8	4.0	0	150	150	150	180	11	NBR	08F23O2140ACF	2
1	1	13.0	5	125	125	125	180	11	NBR	16F24O2164ACF	2
1 1/2	1 1/4	22.5	5	125	125	125	180	11	NBR	24F24O2180ACF	2
DC Voltage											
1/2	5/8	4.0	0	125	125	80	150	11.5	NBR	08F23O2140A3F	3
3/4	3/4	5.5	0	125	125	80	150	11.5	NBR	12F23O2148A3F	3



STAINLESS STEEL

Pipe Size (NPT)	Orifice Size (Inches)	Cv Flow Factor	Min	Max. Pressure Differential			Max. Media Temp. °F	Watt	Seal	Pressure Vessel Catalog Number	Coil Chart
				Air, Inert Gas (PSI)	Water (PSI)	Lt. Oil 300 SSU (PSI)					
AC Voltage											
3/4	3/4	5.5	0	150	150	150	180	11	NBR	12F23O6148ACF	2

2 WAY



2 Way Normally Closed Steam and Hot Water



BRASS

Pipe Size (NPT)	Orifice Size (Inches)	Cv Flow Factor	Min	Max. Pressure Differential			Max. Media Temp. °F	Watt	Seal	Pressure Vessel Catalog Number	Coil Chart
				Steam (PSI)	Hot Water (PSI)	Lt. Oil 300 SSU (PSI)					
AC Voltage											
3/8	1/2	3.0	1	125	-	-	353	11	PTFE	06FS5C2432ACH	see below
1/2	1/2	3.6	1	125	-	-	353	11	PTFE	08FS5C2432ACH	see below
1/2	5/8	4.0	0	50	150	-	300	11	EDPM	08FS3C2340ACF	2
1/2	5/8	4.0	3	125	-	-	353	10	PTFE	73218BN4UTS0	6
3/4	3/4	5.0	0	50	150	-	300	11	EDPM	12FS3C2348ACF	2
3/4	5/8	4.5	3	125	-	-	353	10	PTFE	73218BN5VTS0	6
3/4	5/8	5.0	0	-	100	-	210	10	EDPM	72218BN5VE00	5
3/4	3/4	7.4	1	80	-	-	320	11	PTFE	12FS5C2448ACF	2
1	1	12.2	1	125	-	-	353	11	PTFE	16FS5C2464ACH	see below
1 1/2	1 1/2	22.5	5	50	150	-	300	6	EDPM	24FS4C2380AAF	1



Gold Ring™	Voltage	1/2" NPT Conduit*	DIN
11 Watts Class H	24/60	CH4C01	CHPH01
	120/60	CH4C05	CHPH05
	240/60	CH4C15	CHPH15

* 18" Lead Wires, Nema 1, 2, 3, 4, 4X

2 WAY

Parker 3 Way Normally Closed Direct Acting



BRASS

Pipe Size (NPT)	Orifice Size (Inches)	Cv Flow Factor	Min	Max. Pressure Differential			Max. Media Temp. °F	Watt	Seal	Pressure Vessel Catalog Number	Coil Chart
				Air, Inert Gas (PSI)	Water (PSI)	Lt. Oil 300 SSU (PSI)					
AC Voltage											
1/4	5/64 3/32	.17 .24	0	1150	1150	150	185	10	FKM	7131KBN2JV00	5
1/4	5/64 1/8	.17 .31	0	150	150	150	185	10	FKM	7131TBN2JV00	5
1/4	3/32 9/64	.24 .38	0	110	110	110	185	10	FKM	7131TBN2LV00	5
DC Voltage											
1/4	5/64 3/32	.17 .24	0	150	150	150	185	10	FKM	7131KBN2JV00	5
1/4	5/64 1/8	.17 .31	0	150	150	150	185	10	FKM	7131TBN2JV00	5
1/4	3/32 9/64	.24 .38	0	110	110	110	185	10	FKM	7131TBN2LV00	5



STAINLESS STEEL

Pipe Size (NPT)	Orifice Size (Inches)	Cv Flow Factor	Min	Max. Pressure Differential			Max. Media Temp. °F	Watt	Seal	Pressure Vessel Catalog Number	Coil Chart
				Air, Inert Gas (PSI)	Water (PSI)	Lt. Oil 300 SSU (PSI)					
AC Voltage											
1/8	1/16 1/16	.11 .095	0	200	200	200	185	10	NBR	71315SN1GNJ1	5
1/4	3/64 3/16	.062 .095	0	250	250	250	185	10	NBR	71315SN2ENJ1	5
1/4	1/16 1/16	.11 .095	0	200	200	200	185	10	NBR	71315SN2GNJ1	5
1/4	3/32 3/32	.17 .17	0	125	125	125	185	10	NBR	71315SN2KNJ1	5
1/4	1/8 3/32	.23 .17	0	90	90	90	185	10	NBR	71315SN2MNJ1	5
1/4	1/4 3/32	.67 .17	0	VAC	VAC	VAC	185	10	NBR	71315SN2VNJ1	5
DC Voltage											
1/8	1/16 1/16	.11 .095	0	200	200	200	185	10	NBR	71315SN1GNJ1	5
1/4	3/64 3/16	.062 .095	0	250	250	250	185	10	NBR	71315SN2ENJ1	5
1/4	1/16 1/16	.11 .095	0	200	200	200	185	10	NBR	71315SN2GNJ1	5
1/4	3/32 3/32	.17 .17	0	125	125	125	185	10	NBR	71315SN2KNJ1	5
1/4	1/8 3/32	.23 .17	0	90	90	90	185	10	NBR	71315SN2MNJ1	5
1/4	1/4 3/32	.67 .17	0	VAC	VAC	VAC	185	10	NBR	71315SN2VNJ1	5

3 WAY

Parker 3 Way Normally Open Direct Acting



STAINLESS STEEL

Pipe Size (NPT)	Orifice Size (Inches)	Cv Flow Factor	Min	Max. Pressure Differential			Max. Media Temp. °F	Watt	Seal	Pressure Vessel Catalog Number	Coil Chart
				Air, Inert Gas (PSI)	Hot Water (PSI)	Lt. Oil 300 SSU (PSI)					
AC Voltage											
1/4	1/16 3/64	.10 .05	0	250	250	250	185	10	NBR	71395SN2ENJ1	5
1/4	1/8 1/16	.28 .10	0	150	150	150	185	10	NBR	71395SN2GNJ1	5
DC Voltage											
1/4	1/16 3/64	.10 .05	0	250	250	250	185	10	NBR	71395SN2ENJ1	5
1/4	1/8 1/16	.28 .10	0	150	150	150	185	10	NBR	71395SN2GNJ1	5

3 WAY

Parker 3 Way Multipurpose Direct Acting



BRASS

Pipe Size (NPT)	Orifice Size (Inches)	Cv Flow Factor	Min	Max. Pressure Differential			Max. Media Temp. °F	Watt	Seal	Pressure Vessel Catalog Number	Coil Chart
				Air, Inert Gas (PSI)	Hot Water (PSI)	Lt. Oil 300 SSU (PSI)					
AC Voltage											
1/4	5/64	.17	0	100	100	100	185	10	FKM	7133TBN2JV00	5
DC Voltage											
1/4	5/64	.17	0	100	100	100	185	10	FKM	7133TBN2JV00	5



STAINLESS STEEL

Pipe Size (NPT)	Orifice Size (Inches)	Cv Flow Factor	Min	Max. Pressure Differential			Max. Media Temp. °F	Watt	Seal	Pressure Vessel Catalog Number	Coil Chart
				Air, Inert Gas (PSI)	Hot Water (PSI)	Lt. Oil 300 SSU (PSI)					
AC Voltage											
1/4	1/32 1/32	.024 .024	0	400	400	400	185	10	NBR	71335SN2ANJ1	5
1/4	3/64 3/64	.052 .052	0	180	180	180	185	10	NBR	71335SN2ENJ1	5
1/4	1/16 1/16	.095 .095	0	115	115	115	185	10	NBR	71335SN2GNJ1	5
1/4	3/32 3/32	.17 .17	0	80	80	80	185	10	NBR	71335SN2KNJ1	5
DC Voltage											
1/4	1/32 1/32	.024 .024	0	400	400	400	185	10	NBR	71335SN2ANJ1	5
1/4	3/64 3/64	.052 .052	0	180	180	180	185	10	NBR	71335SN2ENJ1	5
1/4	1/16 1/16	.095 .095	0	115	115	115	185	10	NBR	71335SN2GNJ1	5
1/4	3/32 3/32	.17 .17	0	80	80	80	185	10	NBR	71335SN2KNJ1	5

3 WAY



3 Way Normally Closed Pilot Operated



BRASS

3 WAY

Pipe Size (NPT)	Orifice Size (Inches)	Cv Flow Factor	Min	Max. Pressure Differential			Max. Media Temp. °F	Watt	Seal	Pressure Vessel Catalog Number	Coil Chart
				Air, Inert Gas (PSI)	Water (PSI)	Lt. Oil 300 SSU (PSI)					
AC Voltage											
1/4	1/4	1.20	30	150	-	-	167	10	NBR	73317BN2PN00	5
3/8	3/8	2.1	10	180	180	180	185	10	NBR	73312BN3RNJ0	5
1/2	1/2	3.60	10	180	180	180	185	10	NBR	73312BN4UNJ0	5
3/4	3/4	7.3	10	180	180	180	185	10	NBR	73312BN52NJ0	5
DC Voltage											
1/4	1/4	1.20	30	150	-	-	167	10	NBR	73317BN2PN00	5
3/8	3/8	2.1	10	180	180	180	185	10	NBR	73312BN3RNJ0	5
1/2	1/2	3.60	10	180	180	180	185	10	NBR	73312BN4UNJ0	5
3/4	3/4	7.3	10	180	180	180	185	10	NBR	73312BN52NJ0	5

Parker 4 Way Single Solenoid Direct Acting

BRASS



Pipe Size (NPT)	Orifice Size (Inches)	Cv Flow Factor	Min	Max. Pressure Differential			Max. Media Temp. °F	Watt	Seal	Pressure Vessel Catalog Number	Coil Chart
				Air, Inert Gas (PSI)	Water (PSI)	Lt. Oil 300 SSU (PSI)					
AC Voltage											
1/4	3/16	.75	0	125	125	125	160	24	NBR	71417BN2SN00	see below
1/4	1/16 3/32	.09 .09	10	150	150	150	180	11	NBR	04F48S2106ACF	2
DC Voltage											
1/4	1/16 3/32	.09 .09	10	100	100	100	104	11.5	NBR	04F48S2106A3F	3



Skinner Valve™	Voltage	½" NPT Conduit*
71417BN2SN00 24 watts, Class H	110/50, 120/60 220/50, 240/60	C8GLP3 C8GLQ3

* 18" Lead Wires, Nema 1, 2, 3, 4, 4X

4 WAY

Parker 4 Way Single Solenoid Pilot-Operated



ALUMINUM

Pipe Size (NPT)	Orifice Size (Inches)	Cv Flow Factor	Min	Max. Pressure Differential			Max. Media Temp. °F	Watt	Seal	Pressure Vessel Catalog Number	Coil Chart
				Air, Inert Gas (PSI)	Hot Water (PSI)	Lt. Oil 300 SSU (PSI)					
AC Voltage & DC Voltage											
NAMUR	11/64	.55	30	150	-	-	167	10	NBR	73417AKDKN00	5
NAMUR	11/64	.55	30	150	-	-	167	10	NBR	73417AKDKN7A	5
1/4	1/4	1.0	15	150	-	-	165	10	NBR	73419AN2NNM0	5
1/4	1/4	1.0	15	150	-	-	165	10	NBR	73419AN2NN00	5



BRASS

Pipe Size (NPT)	Orifice Size (Inches)	Cv Flow Factor	Min	Max. Pressure Differential			Max. Media Temp. °F	Watt	Seal	Pressure Vessel Catalog Number	Coil Chart
				Air, Inert Gas (PSI)	Hot Water (PSI)	Lt. Oil 300 SSU (PSI)					
AC & DC Voltage											
NAMUR	1/4	1.2	30	150	-	-	167	10	NBR	73417BKEPN00	5
1/4	1/4	1.2	30	150	-	-	167	10	NBR	73417BN2PN00	5

4 WAY

The following Angle Body Valves are available to ship up to 25 pieces within 24 to 48 hours, upon order placement.



For more information on the new Angle Body Valve line , call 800.825.8305 or to order a catalog please call: 440-205-7799 or e-mail: catalogs@parker.com. Please reference CAT. ABV 0404.

Series 810 Operating Data: Normally Closed, Flow Direction Under Seat: Recommended for liquids and water-hammer application needs

BRONZE BODY VALVES

Port Size	Orifice Size		Flow Coeff		Min	Operating Pressure						Pilot Pressure		Actuator		Valve Number Bronze	Wt. lbs
	DN		Cv	Kv		psi	bar	psi	bar	psi	bar	psi	bar	mm	port		
	inch	(mm)															
1/2	0.59	15	4.1	3.6	0	232	16.0	232	16.0	-	-	51-145	3.5-10	50	1/8	810VBN08T320BH000	2.4
3/4	0.78	20	9.2	8.0	0	190	13.0	190	13.0	-	-	65-145	4.5-10	50	1/8	810VBN12T320BH000	2.6
1	1.00	25	17.3	15.0	0	85	5.8	85	5.8	-	-	65-145	4.5-10	50	1/8	810VBN16T320BH000	3.1

316L STAINLESS STEEL VALVES

Port Size	Orifice Size		Flow Coeff		Min	Operating Pressure						Pilot Pressure		Actuator		Valve Number Stainless	Wt. lbs
	DN		Cv	Kv		psi	bar	psi	bar	psi	bar	psi	bar	mm	port		
	inch	(mm)															
1/2	0.59	15	4.1	3.6	0	320	22.0	320	22.0	-	-	51-145	3.5-10	50	1/8	810VSN08T320BH000	2.4
3/4	0.78	20	9.2	8.0	0	190	13.0	190	13.0	-	-	65-145	4.5-10	50	1/8	810VSN12T320BH000	2.6
1	1.00	25	17.3	15.0	0	85	5.8	85	5.8	-	-	65-145	4.5-10	50	1/8	810VSN16T320BH000	3.1

Pressure ratings reflect standard product offering. Higher pressure ratings are available. Consult Parker.

Series 810 Operating Data: Normally Closed, Flow Direction Over Seat: Recommended for steam and most gases

BRONZE BODY VALVES

Port Size	Orifice Size		Flow Coeff		Min	Operating Pressure						Pilot Pressure		Actuator		Valve Number Bronze	Wt. lbs
	DN		Cv	Kv		psi	bar	psi	bar	psi	bar	psi	bar	mm	port		
	inch	(mm)															
1/2	0.59	15	4.1	3.6	0	232	16.0	-	-	210	14.5	40-145	2.8-10	50	1/8	810VBN08T120BH000	2.4
3/4	0.78	20	9.2	8.0	0	232	16.0	-	-	210	14.5	40-145	2.8-10	50	1/8	810VBN12T120BH000	2.6
1	1.00	25	17.3	15.0	0	232	16.0	-	-	210	14.5	40-145	2.8-10	50	1/8	810VBN16T120BH000	3.1
1-1/2	1.56	40	40.4	35.0	0	232	16.0	-	-	210	14.5	16-145	1.1-10	80	1/4	810VBN24T130BH000	7.9

316L STAINLESS STEEL VALVES

Port Size	Orifice Size		Flow Coeff		Min	Operating Pressure						Pilot Pressure		Actuator		Valve Number Stainless	Wt. lbs
	DN		Cv	Kv		psi	bar	psi	bar	psi	bar	psi	bar	mm	port		
	inch	(mm)															
1/2	0.59	15	4.1	3.6	0	580	40.0	-	-	210	14.5	40-145	2.8-10	50	1/8	810VSN08T120BH000	2.4
3/4	0.78	20	9.2	8.0	0	535	36.8	-	-	210	14.5	40-145	2.8-10	50	1/8	810VSN12T120BH000	2.6
1	1.00	25	17.3	15.0	0	290	20.0	-	-	210	14.5	40-145	2.8-10	50	1/8	810VSN16T120BH000	3.1
1-1/2	1.56	40	40.4	35.0	0	335	23.1	-	-	210	14.5	16-145	1.1-10	80	1/4	810VSN24T130BH000	7.9

Pressure ratings reflect standard product offering. Higher pressure ratings are available. Consult Parker.



Valves that knock out all competitors



Parker's new line of Angle Body Piston valves are versatile and durable. This new line withstands the toughest conditions over millions of cycles. The offering has valves up to 3 inches, a temperature ratings as high as 430 degrees, due to the all-metal construction. This line is available in stainless steel or bronze body, in various actuator materials and a large selection of connections including Tri-clamp and flanged to suit ANSI requirements.



The new Angle Body Valve line consists of two families: the 810 Series On-Off Control valves for industrial applications and the 820 Series Proportional Control valves for process applications. A wide range of control positioner configurations and flow characteristics provide superior performance to satisfy the most difficult conditions including aggressive and viscous fluids and control of steam. The digital microprocessor control valve contains an internal alarm function for valve diagnostics for easy operation.

Offer Of Sale

The items described in this document are hereby offered for sale at prices to be established by Parker Hannifin Corporation, its subsidiaries and its authorized distributors. This offer and its acceptance by any customer ("Buyer") shall be governed by all of the following Terms and Conditions. Buyer's order for any item described in its document, when communicated to Parker Hannifin Corporation, its subsidiary or an authorized distributor ("Seller"] verbally or in writing, shall constitute acceptance of this offer.

1. Terms and Conditions of Sale: All descriptions, quotations, proposals, offers, acknowledgments, acceptances and sales of Seller's products are subject to and shall be governed exclusively by the terms and conditions stated herein. Buyer's acceptance of any offer to sell is limited to these terms and conditions. Any terms or conditions in addition to, or inconsistent with those stated herein, proposed by Buyer in any acceptance of an offer by Seller, are hereby objected to. No such additional, different or inconsistent terms and conditions shall become part of the contract between Buyer and Seller unless expressly accepted in writing by Seller. Seller's acceptance of any offer to purchase by Buyer is expressly conditional upon Buyer's assent to all the terms and conditions stated herein, including any terms in addition to, or inconsistent with those contained in Buyer's offer. Acceptance of Seller's products shall in all events constitute such assent.

2. Payment: Payment shall be made by Buyer net 30 days from the date of delivery of the items purchased hereunder. Any claims by Buyer for omissions or shortages in a shipment shall be waived unless Seller receives notice thereof within 30 days after Buyer's receipt of the shipment. The minimum order amount is \$125.00 net, unless otherwise noted on the quotation .

3. Delivery: Unless otherwise provided on the face hereof, delivery shall be made F.O.B. Seller's plant. Regardless of the method of delivery, however, risk of loss shall pass to Buyer upon Seller's delivery to a carrier. Any delivery dates shown are approximate only and Seller shall have no liability for any delays in delivery. Shipments are made by common carrier. Any premium freight must be requested and paid for by the Buyer.

4. Warranty: Seller warrants that the items sold hereunder shall be free from defects in material or workmanship for a period of 2 years from the date of shipment to Buyer, or 2,000 hours of use, whichever expires first. THIS WARRANTY COMPRISES THE SOLE AND ENTIRE WARRANTY PERTAINING TO ITEMS PROVIDED HEREUNDER. SELLER MAKES NO OTHER WARRANTY, GUARANTEE, OR REPRESENTATION OF ANY KIND WHATSOEVER. ALL OTHER WARRANTIES, INCLUDING BUT NOT LIMITED TO, MERCHANTABILITY AND FITNESS FOR PURPOSE, WHETHER EXPRESS, IMPLIED, OR ARISING BY OPERATION OF LAW, TRADE USAGE, OR COURSE OF DEALING ARE HEREBY DISCLAIMED. NOTWITHSTANDING THE FOREGOING, THERE ARE NO WARRANTIES WHATSOEVER ON ITEMS BUILT OR ACQUIRED WHOLLY OR PARTIALLY, TO BUYER'S DESIGNS OR SPECIFICATIONS.

5. Limitation Of Remedy: SELLER'S LIABILITY ARISING FROM OR IN ANY WAY CONNECTED WITH THE ITEMS SOLD OR THIS CONTRACT SHALL BE LIMITED EXCLUSIVELY TO REPAIR OR REPLACEMENT OF THE ITEMS SOLD OR REFUND OF THE PURCHASE PRICE PAID BY BUYER, AT SELLER'S SOLE OPTION. IN NO EVENT SHALL SELLER BE LIABLE FOR ANY INCIDENTAL, CONSEQUENTIAL OR SPECIAL DAMAGES OF ANY KIND OR NATURE WHATSOEVER, INCLUDING BUT NOT LIMITED TO LOST PROFITS ARISING FROM OR IN ANY WAY CONNECTED WITH THIS AGREEMENT OR ITEMS SOLD HEREUNDER, WHETHER ALLEGED TO ARISE FROM BREACH OF CONTRACT, EXPRESS OR IMPLIED WARRANTY, OR IN TORT, INCLUDING WITHOUT LIMITATION, NEGLIGENCE, FAILURE TO WARN OR STRICT LIABILITY.

6. Changes, Reschedules and Cancellations: Buyer may request to modify the designs or specifications for the items sold hereunder as well as the quantities and delivery dates thereof, or may request to cancel all or part of this order, however, no such requested modification or cancellation shall become part of the contract between Buyer and Seller unless accepted by Seller in a written amendment to this Agreement. Acceptance of any such requested modification or cancellation shall be at Seller's discretion, and shall be upon such terms and conditions as Seller may require.

7. Special Tooling: A tooling charge may be imposed for any special tooling, including without limitation, dies, fixtures, molds and patterns, acquired to manufacture items sold pursuant to this contract. Such special tooling shall be and remain Seller's property notwithstanding payment of any charges by Buyer. In no event will Buyer acquire any interest in apparatus belonging to Seller which is utilized in the manufacture of the items sold hereunder, even if such apparatus has been specially converted or adapted for such manufacture and notwithstanding any charges paid by Buyer. Unless otherwise agreed, Seller shall have the right to alter, discard or otherwise dispose of any special tooling or other property in its sole discretion at any time.

8. Buyer's Property: Any designs, tools, patterns, materials, drawings, confidential information or equipment furnished by Buyer or any other items which become Buyer's property, may be considered obsolete and may be destroyed by Seller after two (2) consecutive years have elapsed without Buyer placing an order for the items which are manufactured using such property. Seller shall not be responsible for any loss or damage to such property while it is in Seller's possession or control.

9. Taxes: Unless otherwise indicated on the face hereof, all prices and charges are exclusive of excise, sales, use, property, occupational or like taxes which may be imposed by any taxing authority upon the manufacture, sale or delivery of the items sold hereunder. If any such taxes must be paid by Seller or if Seller is liable for the collection of such tax, the amount thereof shall be in addition to the amounts for the items sold. Buyer agrees to pay all such taxes or to reimburse Seller therefore upon receipt of its invoice. If Buyer claims exemption from any sales, use or other tax imposed by any taxing authority, Buyer shall save Seller harmless from and against any such tax, together with any interest or penalties thereon which may be assessed if the items are held to be taxable.

10. Indemnity For Infringement of Intellectual Property Rights: Seller shall have no liability for infringement of any patents, trademarks, copyrights, trade dress, trade secrets or similar rights except as provided in this Part 10. Seller will defend and indemnify Buyer against allegations of infringement of U.S. patents, U.S. trademarks, copyrights, trade dress and trade secrets (hereinafter 'Intellectual Property Rights'). Seller will defend at its expense and will pay the cost of any settlement or damages awarded in an action brought against Buyer based on an allegation that an item sold pursuant to this contract infringes the Intellectual Property Rights of a third party. Seller's obligation to defend and indemnify Buyer is contingent on Buyer notifying Seller within ten (10) days after Buyer becomes aware of such allegations of infringement, and Seller having sole control over the defense of any allegations or actions including all negotiations for settlement or compromise. If an item sold hereunder is subject to a claim that it infringes the Intellectual Property Rights of a third party, Seller may, at its sole expense and option, procure for Buyer the right to continue using said item, replace or modify said item so as to make it noninfringing, or offer to accept return of said item and return the purchase price less a reasonable allowance for depreciation. Notwithstanding the foregoing, Seller shall have no liability for claims of infringement based on information provided by Buyer, or directed to items delivered hereunder for which the designs are specified in whole or part by Buyer, or infringements resulting from the modification, combination or use in a system of any item sold hereunder. The foregoing provisions of this Part 10 shall constitute Seller's sole and exclusive liability and Buyer's sole and exclusive remedy for infringement of Intellectual Property Rights.

If a claim is based on information provided by Buyer or if the design for an item delivered hereunder is specified in whole or in part by Buyer, Buyer shall defend and indemnify Seller for all costs, expenses or judgments resulting from any claim that such item infringes any patent, trademark, copyright, trade dress, trade secret or any similar right.

11. Force Majeure: Seller does not assume the risk of and shall not be liable for delay or failure to perform any of Seller's obligations by reason of circumstances beyond the reasonable control of Seller (hereinafter 'events of Force Majeure'). Events of Force Majeure shall include without limitation, accidents, acts of God, strikes or labor disputes, acts, laws, rules or regulations of any government or government agency, fires, floods, delays or failures in delivery of carriers or suppliers, shortages of materials and any other cause beyond Seller's control.

12. Entire Agreement/Governing Law: The terms and conditions set forth herein, together with any amendments, modifications and any different terms or conditions expressly accepted by Seller in writing, shall constitute the entire Agreement concerning the items sold, and there are no oral or other representations or agreements which pertain thereto. This Agreement shall be governed in all respects by the law of the State of Ohio. No actions arising out of the sale of the items sold hereunder or this Agreement may be brought by either party more than two (2) years after the cause of action accrues.

Coils

Please refer to the coil chart number reference within the catalog to find the 24/7 coils available for 24 to 48 hour delivery.



Gold Ring™	Voltage	½" NPT Conduit*	DIN
CHART 1 6 watts, Class F	24/60 120/60, 110/50 240/60, 220/50	AF4C01 AF4C05 AF4C15	AFPH01 AFPH05 AFPH15



Gold Ring™	Voltage	½" NPT Conduit*	DIN
CHART 2 11 watts, Class F	24/60 120/60, 110/50, 240/60, 220/50	CF4C01 CF4C05 CF4C15	CFPH01 CFPH05 CFPH15
CHART 3 11.5 watts, Class F	12VDC 24VDC	3F4C75 3F4C80	3FPH75 3FPH80
CHART 4 16 watts, Class F	24/60 120/60, 110/50 240/60, 220/50	DF4C01 DF4C05 DF4C15	DFPH01 DFPH05 DFPH15



Skinner Valve™	Voltage	½" NPT Conduit*	DIN
CHART 5 10 watt, Class F	24/60 120/60, 110/50 240/60, 220/50 12VDC 24VDC	C111B2 C111P3 C111Q3 C111C1 C111C2	D100B2 D100P3 D100Q3 D100C1 D100C2
CHART 6 10 watt, Class H	24/60 120/60, 110/50 240/60, 220/50 12VDC 24VDC	C222B2 C222P3 C222Q3 C222C1 C222C2	D200B2 D200P3
CHART 7 22 watts, Class H	24/60 120/60, 110/50 12VDC	C322B2 C322P3 C322C1	

* 18" Lead Wires, Nema 1, 2, 3, 4, 4X

Need more information...

Visit our website to download
catalogs and/or catalog pages.



www.parker.com/fcd

Or Call Catalog Services and order
the Skinner Valve™ Catalog (CFL00897),
Gold Ring™ Catalog (7300AC) and
Valve Actuation Catalog (VAP0495).

Tel: 440-205-7799

e-mail: catalogs@parker.com

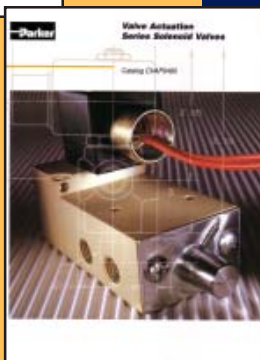
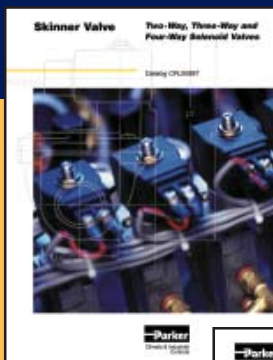

Flip out to
reveal Coil Chart

Quality Policy

“Our goal is to meet or exceed our customers’ expectations through continuous improvement and the elimination of waste.”



WARNING ⚠

FAILURE OR IMPROPER SELECTION OR IMPROPER USE OF THE PRODUCTS AND/OR SYSTEMS DESCRIBED HEREIN OR RELATED ITEMS CAN CAUSE DEATH, PERSONAL INJURY AND PROPERTY DAMAGE.

This document and other information from Parker Hannifin Corporation, its subsidiaries and authorized distributors provide product and/or systems options for further investigation by users having technical expertise. It is important that you analyze all aspects of your application and review the information concerning the product or system in the current product catalog. Due to the variety of operating conditions and applications for these products or systems, the user, through its own analysis and testing, is solely responsible for making the final selection of the products and systems and assuring that all performance, safety and warning requirements of the application are met.

The products described herein, including without limitation, product features, specifications, designs, availability and pricing, are subject to change by Parker Hannifin Corporation and its subsidiaries at anytime without notice.



For more information on locations please call 1.800.C.Parker or visit the Parker website at www.parker.com.

UNITED STATES

Fluid Control Division
95 Edgewood Avenue
New Britain, CT 06051-4107
USA
Tel: 860 827 2300
Fax: 860 827 2384
Email:skinnervalue@parker.com

ARGENTINA

Parker Hannifin Argentina SAIC
Stephenson 2711
1667- Tortuguitas
Malvinas Argentinas
Buenos Aires
Tel: (54) (3327) 44 4129

AUSTRALIA

Parker Hannifin Australia Pty. Ltd.
9, Carrington Road
Castle Hill, N.S.W. 2154
Australia
Tel: 0061 2 9634 7777

BRAZIL

Parker Hannifin Industria e Comercio Ltda.
Av. Lucas Nogueira Garcez 2181
123300-000 Jacarei, SP
Brazil
Tel: (55) 12 354 5216

CANADA

Parker Hannifin Canada
530, Kipling Avenue
Toronto, M8Z 5E6
Tel: (1) 416 255 1585

CHINA REGION

Parker Hannifin Hong Kong Ltd.
8/F, Kin Yip Plaza
9 Cheung Yee Street
Cheung Sha Wan, Kowloon
Hong Kong
Tel: 852 2428 8008

CHINA REGION

Parker Hannifin Beijing Office
Suite B2109, 21st. Floor, Hanwei Plaza
No. 7 Guanghua Road, Chaoyang District
Beijing 100004, P.R. China
Tel: 86 10 6561 0520

Parker Hannifin Shanghai Office
Room 1101, Peregrine Plaza
1325 Huai Hai Road (M)
Shanghai 200031, China
Tel: 86 21 6445 9339

INDIA

Parker Hannifin Corporation
701, Gateway Plaza
Hiranandani Gardens,
Powai, Mumbai- 400 076, India
Tel: (91) 22 570 1671

JAPAN

Parker Hannifin Japan Ltd.
Shirokanedai Building 2nd Floor
3-2-10, Shirokanedai,
Minato-ku, Tokyo 108-0071
Tel: 81 3 6408 3901

KOREA

Parker Hannifin Korea Ltd.
902 Dae Heung Building
Kangnam-Ku
Seoul, Korea 135-080
Tel: 82 31 280 3013

MEDITERRANEAN AREA, MIDDLE EAST AND AFRICA

Parker Hannifin S.p.A
Fluid Control Division-Europe
Via E. Fermi, 5
20060 Gessate (MI) Italy
Tel: 003902 951251

MEXICO-Central-South

Parker Hannifin de Mexico SA DE CV
CIC Group Mexico
Antiguo Camino a San Lorenzo 338
Zona Industrial
Toluca, Mexico CP 50010
Tel: 52 (722) 722222 ext. 213

MEXICO-North

Parker Hannifin de Mexico SA DE CV
CIC Group Mexico
Boulevard Stiva No. 350
Parque Industrial Stiva Aeropuerto
Apodaca, Nuevo Leon
Tel: 52 (81) 83 86 53 14

NEW ZEALAND

Parker Hannifin New Zealand Ltd.
103 Harris Road
East Tamaki
Private Bag 94420
Greenmount
Auckland, New Zealand
Tel: 0064 9 273 8944

SINGAPORE AND SOUTH EAST ASIA

Parker Hannifin Singapore Pte. Ltd.
No. 11, 4th. Chin Bee road
Jurong Town
Singapore 619702
Republic of Singapore
Tel: 0065 261 5233

SOUTH AFRICA

Parker Hannifin Africa Pty. Ltd.
Parker Place
10 Berne Avenue
Aeroporto, Kempton Park
P.O. Box 1153
Kempton Park 1620
Republic of South Africa
Tel: 27 (0) 11 961 0700

TAIWAN

Parker Hannifin Taiwan Co. Ltd.
No. 40, Wu Chiuan 3rd Road
Wuku Industrial Park
Taipei County 248, Taiwan
Republic of China
Tel: 00886 2 2298 8987

VENEZUELA

Parker Hannifin Venezuela S.A.
Edf. Draza, PB 1, Esq. Calle
Miraiama Con Av. Principal
Boleita Norte
Account No. 687716
Caracas, Venezuela
Tel: (58) 2 238 5422



CAT. 24/7 0904